



Washington Association
of Building Officials

The Washington Cities Electrical Code

October 29, 2020



Contents

Preface.....	7
Introduction.....	7
Development.....	7
MyBuildingPermit.com	7
Washington Association of Building Officials	8
Format.....	8
Part 1–Adoption.....	9
Article 80 - Adoption	9
80.1 Short Title	9
80.3 National Electrical Code and Standards Adopted.....	9
80.4 Conflicts	9
Part 2–Administration	10
Article 85 - Administration.....	10
85.1 Purpose	10
85.3 Scope	10
85.5 Applicability	11
85.9 Moved buildings or structures.....	13
85.11 Organization and Enforcement	15
85.13 Permits and Fees	17
85.15 Construction Documents	23
85.17 Approval	28
85.19 Inspections and Testing	30
85.21 Service Utilities.....	35
85.23 Unsafe Systems and Equipment	35
85.25 Violations.....	36
85.27 Means of Appeal.....	38
85.29 Additional Electrical Provisions.....	38
Part 3–NEC Amendments.....	42
90.7 Examination of Equipment for Safety.....	42
100 Definitions	42

110.2 Approval	52
110.3 Examination, Identification, Installation, Use and Listing (Product Certification) of Equipment	52
110.11 Deteriorating Agents	53
110.12 Mechanical Execution of Work	53
110.16 Arc-Flash Hazard Warning	54
110.22 Identification of Disconnecting Means	54
110.30 General	55
210.8 Ground Fault Circuit-Interrupter Protection for Personnel	55
210.11 Branch Circuits Required	56
210.70 Lighting Outlets Required	56
215.10 Ground-Fault Protection of Equipment	56
220.12 Lighting Loads for Specified occupancies.....	57
220.87 Optional Calculations for Determining Existing Loads	57
225.19 Clearances from Buildings for Conductors of Not over 1000 Volts, Nominal	57
225.32 Location	58
230.28 Service Mast as Support.....	59
230.43 Wiring Methods for 1000 Volts, Nominal, or Less	63
230.70 Service Equipment-Disconnecting Means-General	64
230.90 Service Equipment-Overcurrent Protection	64
230.95 Ground Fault Protection of Equipment	65
230.202 Services Exceeding 1000 Volts Service-Entrance Conductors.....	65
240.24 Overcurrent Protection-Location in or on Premises.....	66
250.28 Main Bonding Jumper and System Bonding Jumper	66
250.50 Grounding Electrode System	67
250.53 Grounding Electrode System Installation	67
250.64(B) Grounding Electrode Conductor Installation.....	67
250.104(A) Bonding of Piping Systems and Exposed Structural Steel.....	68
250.104(B) Other Metal Piping.....	68
250.184(A) Solidly Grounded Neutral Systems.....	68
300.4 Protection Against Physical Damage.....	69

Table 300.5 Underground Installations.....	70
300.11 Securing and Supporting	70
311.16 Marking.....	71
312.8 Switch and Overcurrent Device Enclosures.....	71
314.23 Supports	72
314.29 Boxes, Conduit Bodies and Handhole Enclosures to Be Accessible	73
334.10 Nonmetallic-Sheathed Cables: Types NM, NMC, and NMS-Uses Permitted.....	73
334.15 Exposed Work	73
358.10(D) Electrical Metallic Tubing: Type EMT – Wet Locations	73
358.12 Electrical Metallic Tubing: Type EMT - Uses Not Permitted.....	74
394.12 Concealed Knob-and-Tube Wiring - Uses Not Permitted	74
404.3 Enclosure	74
406.12 Tamper Resistant Receptacles.....	75
410.10 Bathtub and Shower Areas.....	75
410.62 Cord Connected Lampholders and Luminaires	75
422.10 Appliances Branch-Circuit Rating.....	76
430.7 Marking on Motors and Multimotor Equipment.....	76
440.14 Air Conditioning and Refrigerating Equipment.....	76
450.27 Oil Insulated Transformers Installed Outdoors	76
450.42 Transformer Vaults - Walls, Roofs and Floors	77
501.200 Sewage Disposal Systems.....	77
514.3 Hazardous (Classified) Locations.....	79
514.11 Circuit Disconnects	79
517.28 Essential Electrical Systems for Hospitals.....	80
519 Educational and Institutional Occupancies	82
525.1 Carnivals, Circuses, Fairs, and Similar Events - Scope	82
547.1 Agricultural Buildings - Scope	82
555 Marinas, Boatyards, Floating Buildings, and Commercial and Noncommercial Docking Facilities	82
590.1 Temporary Installations - Scope.....	84
590.4 Temporary Installations (General) - Splices.....	84

600.3 Electrical Signs and Outline Lighting - Listing	84
600.4 Electrical Signs and Outline Lighting - Markings	84
600.10 Portable or Mobile Signs	85
600.21 Ballasts, Transformers, Class 2 Power Supplies and Electronic Power Supplies	85
600.30 Electrical Signs and Outline Lighting - Applicability	85
680.3 Swimming Pools, Fountains, and Similar Installations - Approval of Equipment.....	85
680.15 Field Installed Equipment	86
680.40 Spas and Hot Tubs - General	86
680.70 Hydromassage Bathtubs - General.....	86
690.2 Solar Photovoltaic Systems - Definitions	87
690.4 Solar Photovoltaic Systems – General Requirements	87
690.7 Solar Photovoltaic Systems - Maximum Voltage.....	87
700.5 Emergency Systems - Transfer Equipment	87
700.7 Emergency Systems - Signs.....	88
700.10 Wiring, Emergency Systems.....	88
700.10(E) Smoke Control Systems, Pressurization Wiring and Equipment.....	89
700.12 Emergency Systems - Sources of Power.....	89
700.32 Emergency Systems - Coordination	90
701.5 Legally Required Standby Systems - Transfer Equipment	90
701.7 Legally Required Standby Systems - Signs	90
701.10 Legally Required Standby Systems - Wiring Legally Required Standby Systems	91
701.12(B) Legally Required Standby Systems - Sources of Power	92
701.32 Legally Required Standby Systems – Selective Coordination	92
702.7 Optional Standby Systems - Signs.....	92
705 Interconnected Electric Power Production Sources	92
705.11 Supply-Side Source Connections.....	93
705.12 Point of Connection.....	93
725.3 Class 1, Class 2, and Class 3 Remote-Control, Signaling, and Power - Limited Circuits Other Articles	93
760.3 Fire Alarm Systems - Other Articles	93
760.12 Fire Alarm Systems.....	94

760.30(A) Boxes.....94
770.3 Optical Fiber Cables - Other Articles94
800.3 Communications Circuits - Other Articles.....95
800.30 Communication Circuits.....95

Preface

Introduction

The Washington Cities Electrical Code is a joint effort between the MyBuildingPermit.com (MBP) E-gov portal and the Washington Association of Building Officials (WABO). This Code was created to provide cities with a document that complies with RCW 19.28.010(3), which allows cities to enforce any Ordinance that is equal, higher or better than the State's rules, but offers the following advantages.

- This Code omits all administrative and procedural State rules that cities cannot or choose not to adopt.
- This Code is written in the same format as the NEC to eliminate any conflict between a State rule and the NEC. This format will also allow the creation of insert pages that can be inserted into the applicable pages of the NEC. This Code provides enforcement consistency among those cities that choose to adopt it.

Development

The partnership between MBP and WABO resulted in an Electrical Committee open to any Washington city and county wishing to participate. The Electrical Committee had participation from Bellevue, Bellingham, Burien, Des Moines, Kirkland, King County, Lacey, Longview, Marysville, Mercer Island, Olympia, Redmond, Renton, SeaTac, Seattle and Vancouver to develop the first edition of this Code. The committee compared the 2020 NEC to the most current State rules and to any regional concerns and through consensus produced the current edition of this Code. All Washington cities are encouraged to adopt this Code.

MyBuildingPermit.com

MyBuildingPermit.com (MBP) is an internet portal currently shared by 13 cities and two counties, with more jurisdictions looking to join. Through the MBP permitting portal, homeowners and contractors can obtain many different types of permits including building, electrical, plumbing, mechanical, reroof, land use, public works and fire permits. Not all jurisdictions allow every permit type to be submitted through the portal, so check with the jurisdiction to find what permit types are available.

Other services provided through the MBP site include:

- Online inspection requests
- Current permit status
- Tip sheets for various construction issues
- Training opportunities

The member jurisdictions are dedicated to providing a consistent and efficient permitting experience to their customers. The current members of MBP are, Bellevue, Bothell, Burien, Edmonds, Issaquah, Kenmore, Kirkland, Mercer Island, Mill Creek, Newcastle, Sammamish, Sea-Tac, Snoqualmie, King County and Snohomish County.

Washington Association of Building Officials

The Washington Association of Building Officials (WABO) was incorporated in 1977 to promote building codes and standards that safeguard the public health and safety; advise on legislative matters; assist in the development of National and State codes; provide educational opportunities for its members; and preserve local government control of code administration.

The WABO is a nonprofit, professional association of state, county, city and town officials in Washington State engaged in the development, enforcement and administration of building construction codes and ordinances. Members (both governmental and associate) are Building Officials and Inspectors, Planners, Architects, Structural Engineers and others interested in providing safe buildings for our communities.

Format

This Code is divided into three parts to facilitate those cities that do not want to adopt the entire document. Part 1 adopts the 2020 NEC and other necessary codes and standards adopted by the State. Part 2 is an administrative chapter based on portions of the ICC Electrical Code, published by the International Code Council. It provides necessary rules for enforcing and administering the NEC. Part 3 amends the NEC through supplements, deletions or revisions to be equal, higher or better than the State's rules. Only those Sections of the NEC that have been amended are included in this Code.

Part 1–Adoption

The National Electrical Code is amended and supplemented by the addition of a new Article to be known as Article 80 – Adoption, to read as follows:

Article 80 - Adoption

80.1 Short Title

These regulations shall be known as the City Electrical Code and shall be cited as such and will be referred to herein as “this code.”

80.3 National Electrical Code and Standards Adopted

The 2020 Edition of the National Electrical Code (NFPA 70-2020) published August, 2019 including Annex A, B and C, and subsequent Errata and Tentative Interim Amendments issued by the National Fire Protection Association; Commercial Building Telecommunications Cabling Standard (ANSI/TIA/EIA 568C series, February 2009 Commercial Building Standard for Telecommunications Pathway and Spaces (ANSI/TIA/EIA 569 B, October 2004); Commercial Building Grounding and Bonding Requirements for Telecommunications (ANSI/ TIA/EIA 607-B, August 2011); and the Residential Telecommunications Cable Standard (ANSI/TIA/EIA 570-B-2004); and the National Electrical Safety Code (NESC C2- 2017 excluding Appendixes A and B) are hereby adopted and shall be applicable within the city, as amended, added to and excepted in this code.

The National Electrical Code will be followed where there is any conflict between the National Electrical Code and ANSI/TIA/EIA 569-B, ANSI/TIA/EIA570-B, or the NESC C2

80.4 Conflicts

In accordance with RCW 19.28.010(3), where the State of Washington, Department of Labor and Industries adopts a more current edition of the National Electrical Code (NFPA 70) the Code Official may supplement use of this Code with newly adopted editions of the National Electrical Code.

Part 2–Administration

The National Electrical Code is amended and supplemented by the addition of a new Article to be known as Article 85 – Administration, to read as follows:

Article 85 - Administration

85.1 Purpose

The purpose of this code is to provide minimum standards to safeguard life or limb, health, property and public welfare by regulating and controlling the design, construction, installation, quality of materials, location, operation, and maintenance or use of electrical systems and equipment.

85.3 Scope

This code covers the installation of electric conductors, electric equipment and additions, alterations, modifications, or repairs to existing electrical installations for the following:

- A. Electric conductors, electric equipment, and electrical raceways installed within or on public and private buildings, property or other structures.
- B. Signaling and communications conductors and equipment, telecommunications conductors and equipment, fiber optic cables, and raceways installed within or on public and private buildings, property or other structures.
- C. Yards, lots, parking lots, and industrial substations.
- D. Temporary electrical installations for use during the construction of buildings.
- E. Temporary electrical installations for carnivals, conventions, festivals, fairs, traveling shows, the holding of religious services, temporary lighting of streets, or other approved uses.
- F. Installations of conductors and equipment that connect to a supply of electricity.
- G. All other outside electrical conductors on the premises.
- H. Optional standby systems derived from portable generators.

Exception: Installations under the exclusive control of electric utilities for the purpose of communication, transmission, and distribution of electric energy located in buildings used exclusively by utilities for such purposes or located outdoors on property owned or leased by the utilities or on public highways, streets, roads, etc., or outdoors by established rights on private property. It is the intent of this section that this code covers all premises' wiring or wiring other than utility owned metering equipment, on the load side of the service point of buildings, structures, or any other premises not owned or leased by the utility.

Also, it is the intent that this code covers installations in buildings used by the utility for purposes other than listed above, such as offices buildings, warehouses, garages, machine shops, and recreational buildings which are not an integral part of a generating plant, substation, or control center.

85.5 Applicability

- A. **New Installations:** This code applies to new electrical installations. Exception: If an electrical permit application is received after this chapter has taken effect, but is associated with a building permit application received prior to the effective date of the ordinance codified in this chapter, all applicable codes adopted and in force at the time of a complete building permit application will apply.
- B. **Existing Installations:** Lawfully installed existing electrical installations that do not comply with the provisions of this chapter shall be permitted to be continued without change, except as specifically covered in this code, the International Fire Code or as is deemed necessary by the Code Official for the general safety and welfare of the occupants and the public. Where changes are required for correction of hazards, a reasonable amount of time shall be given for compliance, depending on the degree of the hazard.
- C. **Maintenance:** Electrical systems, equipment, materials and appurtenances, both existing and new, and parts thereof shall be maintained in proper operating condition in accordance with the original design and in a safe, hazard-free condition. Devices or safeguards that are required by this code shall be maintained in compliance with the code edition under which installed. The owner or the owner's designated agent shall be responsible for the maintenance of the electrical systems and equipment. To determine compliance with this provision, the Code Official shall have the authority to require that the electrical systems and equipment be re-inspected.
- D. **Additions, alterations, modifications or repairs:** Additions, alterations, modifications or repairs to the electrical system of any building, structure, or premises shall conform to the requirements of this Code without requiring those portions of the existing building not being altered or modified to comply with all the requirements of this Code. Installations, additions, alterations, modifications, or repairs shall not cause an existing building to become unsafe or to adversely affect the performance of the building as determined by the Code Official or designated representative. Electrical wiring added to an existing service, feeder, or branch circuit shall not result in an installation that violates the provisions of the Code in force at the time the additions were made.

- E. **Change in occupancy:** It shall be unlawful to make a change in the occupancy of any structure that will subject the structure to any special provision of this Code applicable to the new occupancy without approval. The Code Official shall certify that such structure meets the intent of the provisions of law governing building construction for the proposed new occupancy and that such change of occupancy does not result in any hazard to public health, safety or welfare.
- F. Differences:
- 1) Where, in any specific case, different sections of this Code specify different materials, methods of construction or other requirements, the most restrictive shall govern. Where there is a conflict between a general requirement and a specific requirement, the specific requirement shall be applicable.
 - 2) The requirements of this Code will be observed where there is any conflict between this code and the National Electrical Code (NFPA 70), Centrifugal Fire Pumps (NFPA 20), the Emergency and Standby Power Systems (NFPA 110), ANSI/TIA/EIA 568-B, ANSI/TIA/EIA 569-A, ANSI/TIA/EIA 607, or ANSI/TIA/EIA 570.
 - 3) The National Electrical Code will be followed where there is any conflict between standard for Installation of Stationary Pumps for Fire Protection (NFPA 20), standard for Emergency and Standby Power Systems (NFPA 110), ANSI/TIA/EIA 568-B, ANSI/TIA/EIA 569-A, ANSI/TIA/EIA 607, ANSI/TIA/EIA 570-B, and the National Electrical Code (NFPA 70).
- G. **Other laws:** The provisions of this Code shall not be deemed to nullify any provisions of Local, State or Federal law.
- H. **Validity:** In the event any part or provision of this Code is held to be illegal or void, this shall not have the effect of making void or illegal any of the other parts or provisions thereof, which are determined to be legal; and it shall be presumed that this Code would have been adopted without such illegal or invalid parts or provisions.
- I. **Segregation of invalid provisions:** Any invalid part of this code shall be segregated from the remainder of this Code by the court holding such part invalid, and the remainder shall remain effective.
- J. **Application of references:** References to chapter or section numbers, or to provisions not specifically identified by number, shall be construed to refer to such chapters, sections or provisions of this Code.
- K. **Referenced codes and standards:** The codes and standards referenced in this code shall be considered part of the requirements of this code to the prescribed extent of

each such reference. Where differences occur between provisions of this code and referenced codes or standards, the provisions of this code shall apply.

Exception: Where enforcement of a code provision would violate the conditions of the listing of the equipment or appliance, the conditions of the listing and manufacturer's instructions shall apply.

- L. **Annex Chapters:** Provisions in the annex chapters shall not apply unless specifically referenced in the adopting ordinance.
- M. **Subjects not regulated by this code:** Where no applicable standards or requirements are set forth in this code, or are contained within other laws, codes, regulations, ordinances or bylaws adopted by the jurisdiction, compliance with applicable standards of nationally recognized standards as are approved shall be deemed as prima facie evidence of compliance with the intent of this code. Nothing herein shall derogate from the authority of the Code Official to determine compliance with codes or standards for those activities or installations within the Code Official's jurisdiction or responsibility.

85.9 Moved buildings or structures

- A. Buildings or structures intended to be relocated within or into the city must be inspected by the Code Official for compliance with the codes and standards adopted in this chapter prior to being relocated or moved. The owner of the building or structure must obtain a building permit and further must agree to correct all deficiencies identified by the inspection prior to moving the building. All deficiencies must be corrected before electric power is connected to the building.
- B. Nonresidential buildings or structures moved into the jurisdiction must be inspected to ensure compliance with current requirements of this Code.
- C. Residential buildings or structures wired in the U.S., to NEC requirements, and moved into the jurisdiction must be inspected to ensure compliance with the NEC requirements in effect at the time and place the original wiring was made. The building or structure must be inspected to ensure compliance with all current requirements of chapter 19.28 RCW and the rules developed by the department if:
 - 1) The original occupancy classification of the building or structure is changed as a result of the move; or
 - 2) The building or structure has been substantially remodeled or rehabilitated as a result of the move.
- D. Residential buildings or structures wired in Canada to Canadian Electrical Code (CEC)

standards and moved into the jurisdiction must be inspected to ensure compliance with the following minimum safety requirements:

- 1) Service, service grounding, and service bonding must comply with this Code.
- 2) Canadian Standards Association (CSA) listed Type NMD cable is allowed with the following qualifications:
 - a) CSA listed Type NMD cable, American Wire Gauge #10 and smaller installed after 1964 utilizing an equipment grounding conductor smaller than the phase conductors, must be:
 - i. Replaced with a cable utilizing a full-size equipment grounding conductor; or
 - ii. Protected by a ground fault circuit interrupter protection device.
 - b) CSA listed Type NMD cable, #8 AWG and larger, must:
 - i. Utilize an equipment grounding conductor sized according to the requirements of the NEC in effect at the time of the installation;
 - ii. Be protected by a ground fault circuit interrupter protection device; or
 - iii. Be replaced.
- 3) Other types of wiring and cable must be:
 - a) Replaced with wiring listed or field evaluated in accordance with U.S. standards by a laboratory approved by the department; or
 - b) Protected by a ground fault circuit interrupter protection device and arc fault circuit protection device.
- 4) Equipment, other than wiring or panelboards, manufactured and installed prior to 1997 must be listed and identified by laboratory labels approved by the department or CSA labels.
- 5) All panelboards must be listed and identified by testing laboratory labels approved by the department with the following qualifications:
 - a) CSA listed panelboards labeled "Suitable for Use as Service Equipment" will be considered to be approved as "Suitable for Use only as Service Equipment."
 - b) CSA listed panelboards must be limited to a maximum of 42 circuits.
 - c) CSA listed panelboards used as lighting and appliance panelboards as described in the NEC, must meet all current requirements of the NEC and this chapter.

- 6) Any wiring or panelboards replaced or changed as a result of the move must meet current requirements of chapter 19.28 RCW and this chapter.
- 7) The location, type, and ground fault circuit interrupter protection of receptacles and equipment in a bathroom, kitchen, basement, garage, or outdoor area must meet the Washington requirements in effect at the time the wiring was installed.
- 8) Four, 15-ampere, kitchen small appliance circuits will be accepted in lieu of two, 20-ampere, kitchen small appliance circuits. Receptacles will not be required to be added on kitchen peninsular or island counters.
- 9) Spacing requirements for all other receptacles must meet the Washington requirements in effect at the time the wiring was installed.
- 10) Receptacles installed above baseboard or fixed wall space heaters must be removed and the outlet box covered with a blank cover. The receptacle is required to be relocated as closely as possible to the existing location.
- 11) Lighting outlet and switch locations must meet the City's requirements in effect at the time the wiring was installed.
- 12) Dedicated 20-ampere small appliance circuits are not required in dining rooms.
- 13) Electric water heater branch circuits must be adequate for the load.
- 14) The location, type, and circuit protection of feeders must meet the city's requirements in effect at the time the wiring was installed.

85.11 Organization and Enforcement

- A. Creation of enforcement agency. The department of electrical inspection is hereby created and the Official in charge thereof shall be known as the Code Official. The function of the department shall be to assist the Code Official in the administration and enforcement of the provisions of this Code.
- B. Appointment. The Code Official shall be appointed by the Chief appointing authority of the jurisdiction.
- C. Deputies. In accordance with the prescribed procedures of this jurisdiction and with the concurrence of the appointing authority, the Code Official shall have the authority to appoint a Deputy Code Official, the related technical officers; Inspectors, Plans Examiners and other employees. Such employees shall have powers as delegated by the Code Official.
- D. Duties and powers of the Code Official. The Code Official is hereby authorized and directed to enforce the provisions of this Code. The Code Official shall have the

authority to render interpretations of this Code, and to adopt policies, procedures, rules and regulations in order to clarify the application of its provisions. Such interpretations, policies, procedures, rules and regulations shall be in compliance with the intent and purpose of this Code. Such policies and procedures shall not have the effect of waiving requirements specifically provided for in this Code.

- 1) **Rule-making authority.** The Code Official shall have authority as necessary in the interest of public health, safety and general welfare, to adopt and promulgate rules and regulations and to designate requirements applicable because of local climatic or other conditions. Such rules shall not have the effect of waiving requirements specifically provided for in this Code, or of violating accepted engineering methods involving public safety.
- 2) **Applications and permits.** The Code Official is authorized to receive applications, review construction documents and issue permits for the installation of electrical systems and equipment, inspect the premises for which such permits have been issued, and enforce compliance with the provisions of this Code.
- 3) **Notices and orders.** The Code Official is authorized to issue all necessary notices or orders in accordance with Section 85.25(B) as are required to effect compliance with this Code.
- 4) **Inspections.** The Code Official shall make all of the inspections necessary to determine compliance with the provisions of this Code in accordance with Section 85.19.
- 5) **Identification.** The Code Official shall carry proper identification as required by Section 85.19(G).
- 6) **Right of entry.** The Code Official is authorized to enter the structure or premises at reasonable times to inspect or perform the duties imposed by this Code in accordance with Section 85.19(I).
- 7) **Department records.** The Code Official shall keep official records of applications received, permits and certificates issued, fees collected, reports of inspections, notices and orders issued, and as required by this Code, such records shall be retained in the official records for the period required for retention of public records.
- 8) **Approvals and modifications.** A record of approvals and modifications granted shall be maintained by the Code Official and shall be available for public inspection during business hours in accordance with applicable laws.

- 9) **Inspections.** The Code Official shall keep a record of each inspection made, including notices and orders issued, showing the findings and disposition of each.
- 10) **Alternative methods or materials.** The application for modification, alternative methods or materials and the final decision of the Code Official shall be in writing and shall be officially recorded in the permanent records of the Code Official.
- 11) **Liability.** The Code Official, Officer or employee charged with the enforcement of this Code, while acting for the jurisdiction in good faith and without malice in the discharge of the duties required by this code or other pertinent law or ordinance, shall not thereby be rendered liable personally, and is hereby relieved from all personal liability for any damage accruing to persons or property as a result of any act or by reason of an act or omission in the discharge of official duties. Any suit instituted against any Officer or employee because of an act performed by that Officer or employee in the lawful discharge of duties and under the provisions of this Code shall be defended by the legal representative of the jurisdiction until the final termination of the proceedings.

The Code Official or any subordinate shall not be liable for costs in any action, suit or proceeding that is instituted in pursuance of the provisions of this Code; and any Official, Officer or employee, acting in good faith and without malice, shall be free from liability for acts performed under any of its provisions or by reason of any act or omission in the performance of official duties in connection therewith.

- E. **Certificate of Occupancy.** No building or structure shall be used or occupied until a certificate of occupancy has been provided in accordance with the International Building Code.

85.13 Permits and Fees

- A. **Permits required.** Permits required by this Code shall be obtained from the Code Official. Permit fees, if any, shall be paid prior to issuance of the permit. Issued permits shall be kept on the premises designated therein at all times and shall be readily available for inspection by the Code Official.
- B. **Types of permits.** An owner, authorized agent or contractor who desires to construct, enlarge, alter, repair, move, demolish or change the occupancy of a building or structure, or to erect, install, enlarge, alter, repair, remove, convert or replace electrical systems or equipment, the installation of which is regulated by this code, or to cause such work to be done, shall first make application to the Code Official and obtain the required permit for the work.

Exception: Where repair or replacement of electrical systems or equipment must be performed in an emergency situation, the permit application shall be submitted within the next working business day.

- C. **Telecommunication Systems.** An electrical permit is required for all installations of telecommunications systems on the customer side of the network demarcation point for projects greater than ten telecommunications outlets. All backbone installations regardless of size and all telecommunications cable or equipment installations involving penetrations of fire barriers or passing through hazardous locations require permits and inspections. For the purposes of determining the inspection threshold for telecommunications projects greater than ten outlets, the following will apply:
- 1) An outlet is the combination of jacks and mounting hardware for those jacks, along with the associated cable and telecommunications closet terminations that serve one workstation. In counting outlets to determine the inspection threshold, one outlet must not be associated with more than six standard four pair cables or more than one twenty five-pair cable. Therefore, installations of greater than sixty standard four-pair cables or ten standard twenty-five-pair cables require permits and inspections. (It is not the intent of the statute to allow large masses of cables to be run to workstations or spaces serving telecommunications equipment without inspection. Proper cable support and proper loading of building structural elements are safety concerns. When considering total associated cables, the telecommunications availability at one workstation may count as more than one outlet.)
 - 2) The installation of greater than ten outlets and the associated cables along any horizontal pathway from a telecommunications closet to work areas during any continuous ninety-day period requires a permit and inspection.
 - 3) All telecommunications installations within the residential dwelling units of single-family, duplex, and multifamily dwellings do not require permits or inspections. In residential multifamily dwellings, permits and inspections are required for all backbone installations, all fire barrier penetrations, and installations of greater than ten outlets in common areas.
 - 4) No permits or inspections are required for installation or replacement of cord and plug connected telecommunications equipment or for patch cord and jumper cross-connected equipment.
 - 5) Definitions of telecommunications technical terms will come from chapter 19.28 RCW, this chapter, TIA/EIA standards, and NEC.

D. **Temporary Installations:** For temporary electrical installations, the city will consider a permit applicant to be the owner per RCW 19.28.261 under the conditions below:

Any person firm, partnership, corporation or other entity registered as a general contractor under chapter 18.27 RCW will be permitted to install a single electrical service per address for the purposes of temporary power during the construction phase of a project, when all of the following conditions are met:

- 1) The installation is limited to the mounting and bracing of a preassembled pole or pedestal mounted service, the installation of a ground rod or ground plate, and the connection of the grounding electrode conductor to the ground rod or plate;
- 2) The total service size does not exceed 200 amperes, 250 volts nominal;
- 3) The service supplies no feeders;
- 4) Branch circuits not exceeding 50 amperes each are permitted, provided such branch circuits supply only receptacles that are either part of the service equipment or are mounted on the same pole;
- 5) The General Contractor owns the electrical equipment;
- 6) The General Contractor has been hired by the property owner as the General Contractor for the project;
- 7) The General Contractor must purchase an electrical work permit for the temporary service, request inspection, and obtain approval prior to energizing the service.

E. **Work exempt from permit.** As required by chapter 19.28 RCW or this chapter, an electrical permit is required for the installation, alteration, or maintenance of all electrical systems or equipment except for:

- 1) Travel trailers;
- 2) Basic electrical work which includes:
 - a) The like-in-kind replacement of a: Contactor, relay, timer, starter, circuit board, or similar control component; household appliance; circuit breaker; fuse; residential luminaire; lamp; snap switch; dimmer; receptacle outlet; thermostat; heating element; luminaire ballast with an exact same ballast; component(s) of electric signs, outline lighting, skeleton neon tubing when replaced on-site by an appropriate electrical contractor and when the sign, outline lighting or skeleton neon tubing electrical system is not modified; ten horsepower or smaller motor;
 - b) Induction detection loops described in WAC 296-46B-300(2) and used to control gate access devices; and c) Heat cable repair

- 3) All wiring for low voltage installations within a one or two family dwelling unit or its accessory structure except wired security, fire or smoke alarm systems, provided the power is supplied by a listed Class 2 power supply and none of the wiring penetrates the wall or ceiling separating the two units.

Unless specifically noted, the exemptions listed do not include: The replacement of an equipment unit, assembly, or enclosure that contains an exempted component or combination of components. (i.e., electrical furnace/heat pumps, industrial milling machine, etc.)

Exemption from the permit requirements of this Code shall not be deemed to grant authorization for work to be done in violation of the provisions of this Code or other laws or ordinances of this jurisdiction.

F. **Application.** Application for a permit required by this Code shall be made to the Code Official in such form and detail as prescribed by the Code Official. Applications for permits shall be accompanied by such plans as prescribed by the Code Official.

- 1) **Action on application.** The Code Official shall examine or cause to be examined applications for permits and amendments thereto within a reasonable time after filing. If the application or the construction documents do not conform to the requirements of pertinent laws, the Code Official shall reject such application in writing, stating the reasons therefore. If the Code Official is satisfied that the proposed work conforms to the requirements of this Code and laws and ordinances applicable thereto, the Code Official shall issue a permit as soon as practicable.
- 2) **Inspection required.** Before a permit is issued, the Code Official is authorized to inspect and approve the systems, equipment, buildings, devices, premises and spaces or areas to be used.
- 3) **Time limitation of application.** An application for a permit for any proposed work or operation shall be deemed to have been abandoned 180 days after the date of filing, unless such application has been pursued in good faith or a permit has been issued; except that the Code Official is authorized to grant one extension of time for an additional period not exceeding 90 days. The extension shall be requested in writing and justifiable cause demonstrated.

G. **Conditions of a permit.** A permit shall constitute permission to conduct work as set forth in this Code in accordance with the provisions of this Code. Such permission shall not be construed as authority to violate, cancel or set aside any of the provisions of this Code or other applicable regulations or laws of the jurisdiction.

- H. **Expiration.** Every permit issued shall become invalid unless the work on the site authorized by such permit is commenced within 180 days after its issuance, or if the work authorized on the site by such permit is suspended or abandoned for a period of 180 days after the time the work is commenced. The Code Official is authorized to grant, in writing, one or more extensions of time, for periods not more than 180 days each. The extension shall be requested in writing and justifiable cause demonstrated.
- I. **Extensions.** The Code Official is authorized to grant, in writing, one or more extensions of the time period of a permit for periods of not more than 90 days each. Such extensions shall be requested by the permit holder in writing and justifiable cause demonstrated.
- J. **Posting the permit.** Issued permits shall be kept on the premises designated therein at all times and shall be readily available for inspection by the Code Official.
- K. **Validity.** The issuance or granting of a permit shall not be construed to be a permit for, or an approval of, any violation of any of the provisions of this code or of any other ordinance of the City. Permits presuming to give authority to violate or cancel the provisions of this code or other ordinances of the City shall not be valid. The issuance of a permit based on construction documents and other data shall not prevent the Code Official from requiring the correction of errors in the construction documents and other data. The Code Official is also authorized to prevent occupancy or use of a structure that is in violation of this Code or of any other ordinances of this City.
- L. **Information on the permit.** The Code Official shall issue all permits required by this Code on an approved form furnished for that purpose. The permit shall contain a general description of the operation or occupancy and its location and any other information required by the Code Official.
- M. **Suspension or revocation.** The Code Official is authorized to suspend or revoke a permit issued under the provisions of this Code wherever the permit is issued in error, on the basis of incorrect, inaccurate or incomplete information; in violation of any ordinance, regulation or any of the provisions of this Code; or if any one of the following conditions exists:
- 1) The permit is used for a location or establishment other than that for which it was issued.
 - 2) The permit is used for a condition or activity other than that listed in the permit.
 - 3) Conditions and limitations set forth in the permit have been violated.

- 4) There have been any false statements or misrepresentations as to the material fact in the application for permit or plans submitted or a condition of the permit.
- 5) The permit is used by a different person or firm than the name for which it was issued.
- 6) The permittee failed, refused or neglected to comply with orders or notices duly served in accordance with the provisions of this code within the time provided therein.
- 7) The permit was issued in error or in violation of an ordinance, regulation or this Code.

N. FEES

- 1) **Payment of fees.** A permit shall not be valid until the fees prescribed by law have been paid. Nor shall an amendment to a permit be released until the additional fee, if any, has been paid.
- 2) **Schedule of permit fees.** A fee for each permit shall be paid as required, in accordance with the schedule as established by the City.
- 3) **Work commencing before permit issuance.** Except where authorized for emergencies by Section 85.13(B) exception, any person who commences any work before obtaining the necessary permits shall be subject to an additional fee established by the Code Official, which shall be in addition to the required permit fees.
- 4) **Related fees.** The payment of the fee for the construction, alteration, removal or demolition for work done in connection with, or concurrently with, the work authorized by a permit shall not relieve the applicant or holder of the permit from the payment of other fees that are prescribed by law.
- 5) **Refunds.** The Code Official may authorize refunding of not more than 80 percent of the permit fee paid when no work has been done under a permit issued in accordance with this code provided the request is made in writing and filed by the original permittee not later than 180 days after the date of permit issuance. The Code Official may authorize refunding of not more than 80 percent of the plan review fee paid when an application for a permit for which a plan review fee has been paid is withdrawn or canceled before any plan review is done provided the request is made in writing and filed by the original applicant not later than 180 days after the date of application.

- 6) **Use of Consultants.** Whenever review of an application requires retention by the City for professional consulting services for other than normal plan review, the applicant shall reimburse the City the cost of such professional consulting services. This fee may be in addition to the normal plan review and permit fees. The City may require the applicant to deposit an amount with the City to be sufficient to cover anticipated costs to retain professional consultant services and to ensure reimbursement for such costs.

85.15 Construction Documents

- A. **Submittal documents.** Construction documents, special inspection and structural observation programs, and other data shall be submitted as required by the City in two or more sets with each application for a permit. The construction documents shall be prepared by a registered design professional where required by the State of Washington. Where special conditions exist, the Code Official is authorized to require additional construction documents to be prepared by a registered design professional.

Exception: The Code Official is authorized to waive the submission of construction documents and other data not required to be prepared by a registered design professional if it is found that the nature of the work applied for is such that reviewing of construction documents is not necessary to determine compliance with this code.

- B. **Electrical Engineer.** Electrical plans for the following installations shall be prepared by, or under the direction of an electrical engineer registered under Chapter 18.43 RCW, and Chapters 180-29, 246-320, and 388-97 WAC. All electrical plans must bear the engineer's stamp and signature.

- 1) All educational facilities, hospitals and nursing homes;
- 2) All services or feeders rated 1,600 amperes or larger;
- 3) All installations identified in the National Electrical Code requiring engineering supervision;
- 4) As required by the Building Official for installations which by their nature are complex, hazardous or pose unique design problems.

- C. **Information on construction documents.** Construction documents shall be drawn to scale upon suitable material. Electronic media documents are permitted to be submitted where approved by the Code Official. Construction documents shall be of sufficient clarity to indicate the location, nature and extent of the work proposed and show in detail that it will conform to the provisions of this code and relevant laws, ordinances, rules and regulations, as determined by the Code Official.

Construction documents shall identify the name and classification of the facility and clearly show the electrical installation or alteration in floor plan view, include all switchboard and panelboard schedules and when a service or feeder is to be installed or altered, must include a riser diagram, load calculation, fault current calculation, and interrupting rating of equipment.

- D. **Penetrations.** Construction documents shall indicate where penetrations will be made for electrical systems and shall indicate the materials and methods for maintaining required structural safety, fire resistance rating and fire blocking.
- E. **Load calculations.** Where an addition or alteration is made to an existing electrical system, an electrical load calculation shall be prepared to determine if the existing electrical service has the capacity to serve the added load.
- F. **Site plan.** The construction documents submitted with the application for permit shall be accompanied by a site plan showing to scale the size and location of new construction and existing structures on the site, distances from lot lines, the established street grades and the proposed finished grades; and it shall be drawn in accordance with an accurate boundary line survey. In the case of demolition, the site plan shall show construction to be demolished and the location and size of existing structures and construction that are to remain on the site or plot. The Code Official is permitted to waive or modify the requirement for a site plan where the application for permit is for alteration or repair or where otherwise warranted.
- G. **Plan review required.** Electrical plan review is required for all new or altered electrical projects in the following occupancies and/or installations:
 - 1) Educational, institutional, or health care facilities/buildings as follows:
 - a) Hospital
 - b) Nursing home unit or long-term care unit
 - c) Boarding home
 - d) Assisted living facility
 - e) Private alcoholism hospital
 - f) Alcoholism treatment facility
 - g) Private psychiatric hospital
 - h) Maternity home
 - i) Ambulatory surgery facility

- j) Renal hemodialysis clinic
- k) Residential treatment facility for psychiatrically impaired children and youth
- l) Adult residential rehabilitation center
- m) Educational facilities
- n) Institutional facilities

Exception: Electrical Plan review is not required for the above educational, institutional, or health care facilities buildings where:

- i. Lighting specific projects that result in an electrical load reduction on each feeder involved in the project;
 - ii. Low voltage systems;
 - iii. Modification to existing electrical installations where all of the following conditions are met:
 - a) Service or distribution equipment involved is rated less than 100 amperes and does not exceed 250 volts;
 - b) Does not involve emergency systems other than listed unit equipment per NEC 700.12(F);
 - c) Does not involve branch circuits or feeders of an essential electrical system as defined in NEC 517.2; and
 - d) Service and feeder load calculations are increased by 5 percent or less.
 - iv. Stand-alone utility fed services that do not exceed 250 volts and less than 100 amperes where the project's distribution system does not include:
 - a) Emergency systems other than listed unit equipment per NEC 700.12(F);
 - b) Critical branch circuits or feeders as defined in NEC 517.2, or
 - c) A required fire pump system.
- 1) Installations in occupancies, except one and two family dwellings, where a service or feeder rated 100 amperes or greater is installed or altered or if more than 100 amperes is added to the service or feeder, except temporary services less than 480 volts.
 - 2) All work on electrical systems operating at/over 600 Volts

- 3) All commercial generator installations or alterations
 - 4) All work in areas determined to be hazardous (classified) location by the NEC.
 - 5) Installations of switches or circuit breakers rated four hundred amperes or over except for one and two family dwellings.
 - 6) If 50 percent or more of luminaires change and there is an increase in the lighting load.
 - 7) Wind driven generators.
 - 8) Solar photovoltaic systems.
 - 9) Any proposed installation which cannot be adequately described in the application form.
- H. **Examination of Documents.** The Code Official shall examine or cause to be examined the accompanying construction documents and shall ascertain by such examinations whether the construction indicated and described is in accordance with the requirements of this code and other pertinent laws or ordinances.
- I. **Approval of construction documents.** When the Code Official issues a permit, the construction documents shall be approved, in writing or by stamp, as "Reviewed By," "Approved" or other similar words. One set of construction documents so reviewed shall be retained by the Code Official. The other set shall be returned to the applicant, shall be kept at the site of work and shall be open to inspection by the Code Official or the authorized representative.
- 1) Previous approvals. This code shall not require changes in the construction documents, construction or installation of electrical systems or equipment for which a lawful permit has been heretofore issued or otherwise lawfully authorized, and the construction of which has been pursued in good faith within 180 days after the effective date of this code and has not been abandoned.
 - 2) Phased approval. The Code Official is authorized to issue a permit for the installation of part of an electrical system before the construction documents for the electrical system have been submitted, provided that adequate information and detailed statements have been filed complying with pertinent requirements of this code. The holder of such permit shall proceed at the holder's own risk with the building operation and without assurance that a permit for the entire system will be granted.

- J. **Design Professional in Responsible Charge.** When it is required that documents be prepared by a qualified registered design professional, the Building Official shall be authorized to require the owner to engage and designate on the building permit application a registered design professional who shall act as the registered design professional in responsible charge. If the circumstances require, the owner shall designate a substitute registered design professional in responsible charge who shall perform the duties required of the original registered design professional in responsible charge. The Building Official shall be notified in writing by the owner if the registered design professional in responsible charge is changed or is unable to continue to perform the duties. The registered design professional in responsible charge shall be responsible for reviewing and coordinating submittal documents prepared by others, including phased and deferred submittal items, for compatibility with the design of the building. Where structural observation is required by IBC Chapter 17, the inspection program shall name the individual or firms who are to perform structural observation and describe the stages of construction at which structural observation is to occur (see also duties specified in IBC Chapter 17).
- K. **Deferred submittals.** For the purposes of this section, deferred submittals are defined as those portions of the design that are not submitted at the time of the application and that are to be submitted to the Building Official within a specified period. Deferral of any submittal items shall have the prior approval of the Building Official. The registered design professional in responsible charge, or the applicant, if no design professional is required, shall list the deferred submittals on the construction documents for review by the Building Official. Where a design professional is required, documents for deferred submittal items shall be submitted to the registered design professional in responsible charge who shall review them and forward them to the Building Official with a notation indicating that the deferred submittal documents have been reviewed and been found to be in general conformance to the design of the building. The deferred submittal items shall not be installed until the design and submittal documents have been approved by the Building Official. The Building Official is authorized to charge an additional plan review fee to evaluate the deferred submittal under.
- L. **Amended construction documents (aka "Revisions").** Work shall be installed in accordance with the approved construction documents, and any changes made during construction that are not in compliance with the approved construction documents shall be resubmitted for approval as an amended set of construction documents (aka: Revisions). The Building Official may authorize minor field changes subject to the approval of the Field Inspector.

- M. **Retention of construction documents.** One set of approved construction documents shall be retained by the City for a period of not less than 180 days from date of completion of the permitted work, or as required by state or local laws.

85.17 Approval

- A. **Approved materials and equipment.** All materials, equipment and devices approved by the Code Official shall be constructed and installed in accordance with such approval.
- B. **Technical assistance.** To determine the acceptability of technologies, processes, products, facilities, materials and uses attending the design, operation or use of a building or premises subject to the inspection of the department, the Code Official is authorized to require the owner or the person in possession or control of the building or premises to provide, without charge to the jurisdiction, a technical opinion and report. The opinion and report shall be prepared by a qualified engineer, specialist, laboratory or organization acceptable to the Code Official and shall analyze the properties of the design, operation or use of the building or premises and the facilities and appurtenances situated thereon, to recommend necessary changes. The Code Official is authorized to require design submittals to be prepared by and bear the stamp of a registered design professional.
- C. **Modifications.** Wherever there are practical difficulties involved in carrying out the provisions of this code, the Code Official shall have the authority to grant modifications for individual cases, provided the Code Official shall first find that special individual reason makes the strict letter of this code impractical and that the modification is in compliance with the intent and purpose of this code, and that such modification does not lessen health, life and fire-safety requirements. The details of action granting modifications shall be recorded and entered in the permitfile.
- D. **Alternative materials, methods, equipment and appliances.** The provisions of this code are not intended to prevent the installation of any material or to prohibit any method of construction not specifically prescribed by this code, provided that any such alternative has been approved. An alternative material or method of construction shall be approved where the Code Official finds that the proposed design is satisfactory and complies with the intent of the provisions of this code, and that the material, method or work offered is, for the purpose intended, at least the equivalent of that prescribed in this code in quality, strength, effectiveness, fire resistance, durability and safety.

- E. **Material, equipment and appliance reuse.** Materials, equipment, appliances and devices shall not be reused unless such elements have been reconditioned, tested and placed in good and proper working condition and approved.
- F. **Required testing.** Wherever there is insufficient evidence of compliance with the provisions of this code, or evidence that a material or method does not conform to the requirements of this code, or in order to substantiate claims for alternative materials or methods, the Code Official shall have the authority to require tests as evidence of compliance to be made at no expense to the jurisdiction.
- G. **Test methods.** Test methods shall be as specified in this code or by other recognized test standards. In the absence of recognized and accepted test methods, the Code Official shall approve the testing procedures.
- H. **Testing agency.** All tests shall be performed by an approved agency.
- I. **Test reports.** Reports of tests shall be retained by the Code Official for the period required for retention of public records.
- J. **Alternate engineered design.** The design, documentation, inspection, testing and approval of an alternative engineered design electrical system shall comply with this section.
 - 1) **Design criteria.** An alternative engineered design shall conform to the intent of the provisions of this code and shall provide an equivalent level of quality, strength, effectiveness, fire resistance, durability and safety. Materials, equipment or components shall be designed and installed in accordance with the manufacturer's installation instructions.
 - 2) **Submittal.** The registered design professional shall indicate on the permit application that the electrical system is an alternative engineered design. The permit and permanent permit records shall indicate that an alternative engineered design was part of the approved installation.
 - 3) **Technical data.** The registered design professional shall submit sufficient technical data to substantiate the proposed alternative engineered design and to prove that the performance meets the intent of this code.
 - 4) **Construction documents.** The registered design professional shall submit to the Code Official two complete sets of signed and sealed construction documents for the alternative engineered design. The construction documents shall include floor plans and a diagram of the work.

- 5) **Design approval.** Where the Code Official determines that the alternative engineered design conforms to the intent of this code, the electrical system shall be approved. If the alternative engineered design is not approved, the Code Official shall notify the registered design professional in writing, stating the reasons therefore.
- 6) **Inspection and testing.** The alternative engineered design shall be tested and inspected in accordance with the requirements of this code.

85.19 Inspections and Testing

- A. **General.** The Code Official is authorized to conduct inspections that are deemed necessary to determine the extent of compliance with the provisions of this code and to approve reports of inspection by approved agencies or individuals. All reports of such inspections shall be prepared and submitted in writing for review and approval. Inspection reports shall be certified by a responsible officer of such approved agency or by the responsible individual. The Code Official is authorized to engage such expert opinion as deemed necessary to report upon unusual, detailed or complex technical issues subject to the approval of the governing body. Electrical wiring or equipment subject to this chapter must be sufficiently accessible, at the time of inspection, to allow the inspector to visually inspect the installation to verify conformance with the NEC and any other electrical requirements of this chapter. Cables or raceways, fished according to the NEC, do not require visual inspection.
- B. **Required Inspections.** The Code Official, upon notification, shall make the inspections set forth in this section:
 - 1) **Underground.** Underground inspection shall be made after trenches or ditches are excavated and bedded, piping and conductors are installed, and before backfill is put in place. Where excavated soil contains rocks, broken concrete, frozen chunks and other rubble that would damage or break the raceway, cable or conductors, or where corrosive action will occur, protection shall be provided in the form of granular or selected material, approved running boards, sleeves or other means.
 - 2) **Rough-in.** Rough-in inspection shall be made after the roof, framing, fireblocking and bracing are in place and all wiring and other components to be concealed are complete, and prior to the installation of wall or ceiling membranes. All required equipment grounding conductors installed in concealed cable or flexible conduit systems must be completely installed and made up at the time of the rough-in cover inspection.

- 3) Other inspections. In addition to the inspections specified above, the Code Official is authorized to make or require other inspections of any construction work to ascertain compliance with the provisions of this code and other laws, which are enforced by the department of electrical inspection.
 - 4) Final Inspection. The final inspection shall be made after all work required by the permit is completed.
- C. **Concealed work.** Work shall remain accessible and exposed for inspection purposes until approved. It shall be the duty of the permit applicant to cause the work to remain accessible and exposed for inspection purposes. Wherever any installation subject to inspection prior to use is covered or concealed without having first been inspected, the Code Official shall have the authority to require that such work be exposed for inspection. Neither the Code Official nor the jurisdiction shall be liable for expense entailed in the removal or replacement of any material required to allow inspection.
- D. **Inspection record card.** Work requiring a permit shall not be commenced until the permit holder or an agent of the permit holder shall have posted or otherwise made available an inspection record card such as to allow the Code Official to make conveniently the required entries thereon regarding inspection of the work. This card shall be maintained by the permit holder until final approval has been granted by the Code Official.
- E. **Approval required.** Work shall not be performed beyond the point indicated in each successive inspection and test without first obtaining the approval of the Code Official. The Code Official, upon notification, shall make the requested inspections and tests and shall either indicate the portion of the construction that is satisfactory as completed, or shall notify the permit holder or an agent of the permit holder wherein the same fails to comply with this code. Any portions that do not comply shall be corrected and such portion shall not be covered or concealed until authorized by the Code Official. Approval as a result of an inspection shall not be construed to be an approval of a violation of the provisions of this code or of other ordinances of the jurisdiction. Inspections presuming to give authority to violate or cancel the provisions of this code or of other ordinances of the jurisdiction shall not be valid.
- F. **Preliminary inspection.** Before issuing a permit, the Code Official is authorized to examine or cause to be examined buildings, structures and sites for which an application has been filed. The Code Official shall be notified when the installation is ready for inspection and is authorized to conduct the inspection within a reasonable period of time.

- G. **Identification.** The Code Official shall carry proper identification issued by the governing authority where inspecting structures, premises or facilities in the performance of duties under this code and shall be identified by proper credentials issued by this governing authority.
- H. **Impersonation prohibited.** A person shall not impersonate the Code Official through the use of a uniform, identification card, badge or any other means.
- I. **Right of entry.** Where it is necessary to make an inspection to enforce the provisions of this code, or where the Code Official has reasonable cause to believe that there exists in a structure or upon any premises a condition that is contrary to or in violation of this code, which makes the structure or premises unsafe, dangerous or hazardous, the Code Official is authorized to enter the structure or premises at reasonable times to inspect or to perform the duties imposed by this code, provided that if such structure or premises be occupied, that credentials be presented to the occupant and entry requested. If such structure or premises is unoccupied, the Code Official is authorized to first make a reasonable effort to locate the owner or other person having charge or control of the structure or premises and request entry. If entry is refused, the Code Official shall have recourse to the remedies provided by law to secure entry.
- J. **Inspection agencies.** The Code Official is authorized to accept reports of approved inspection agencies, provided such agencies satisfy the requirements as to qualifications and reliability.
- K. **Inspection requests.** It shall be the duty of the person doing the work authorized by a permit or the owner to notify the Code Official that such work is ready for inspection. It shall be the duty of the person requesting any inspections required by this code to provide access to and means for inspection of such work. Requests for inspections must be made no later than three business days after completion of the electrical/telecommunications installation or one business day after any part of the installation has been energized, whichever occurs first.
- L. **Assistance from other agencies.** The assistance and cooperation of police, building, fire and health department officials and all other officials shall be available as required in the performance of duties.
- M. **Contractors' responsibilities.** It shall be the responsibility of every contractor who enters into contracts for the installation or repair of electrical systems for which a permit is required to comply with adopted state and local rules and regulations concerning licensing.

N. Traffic management systems.

- 1) The city will perform the electrical inspection and acceptance of traffic management systems within its jurisdiction. A traffic management system includes:
 - a) Traffic illumination systems;
 - b) Traffic signal systems;
 - c) Traffic monitoring systems;
 - d) The electrical service cabinet and all related components and equipment installed on the load side of the service cabinet supplying electrical power to the traffic management system; and
 - e) Signalization system(s) necessary for the operation of a light rail system. A traffic management system can provide signalization for controlling vehicular traffic, pedestrian traffic, or rolling stock.
- 2) The city recognizes that traffic signal conductors, pole and bracket cables, signal displays, traffic signal controllers/cabinets, and associated components used in traffic management systems are acceptable for the purpose of meeting the requirements of chapter 19.28 RCW provided they conform with the following standards or are listed on the Washington state department of transportation (WSDOT) qualified products list.
 - a) WSDOT/APWA Standard Specifications and Plans;
 - b) WSDOT Design Manual;
 - c) International Municipal Signal Association (IMSA);
 - d) National Electrical Manufacturer's Association (NEMA);
 - e) Federal Standards 170/Controller Cabinets;
 - f) Manual for Uniform Road, Bridge, and Municipal Construction;
 - g) Institute of Transportation Engineers (ITE); or
 - h) Manual of Uniform Traffic Control Devices (MUTCD).
- 3) Associated induction detection loop or similar circuits will be accepted by the department or city authorized to do electrical inspections without inspection.
- 4) For the licensing requirements of chapter 19.28 RCW, jurisdictions will be considered owners of traffic management systems when doing electrical work for other jurisdiction(s) under a valid interlocal agreement, as permitted by chapter

39.34 RCW. Interlocal agreements for traffic management systems must be filed with the department or city authorized to do electrical inspections prior to work being performed for this provision to apply.

- 5) Jurisdictions, with an established electrical inspection authority, and WSDOT may perform electrical inspection on their rights of way for each other by interlocal agreement. They may not perform electrical inspection on other rights of way except as allowed in chapter 19.28 or 39.34 RCW.
 - 6) Underground installations.
 - a) In other than open trenching, raceways will be considered “fished” according to the NEC and do not require visual inspection.
 - b) The department or city authorized to do electrical inspections will conduct inspections in open trenching within its jurisdiction upon request.
 - 7) Identification of traffic management system components. Local government jurisdictions or WSDOT may act as the certifying authority for the safety evaluation of all components.
 - a) An electrical service cabinet must contain only listed components. The electrical service cabinet enclosure is not required to be listed but will conform to the standards in subsection (h) of this section. (b) The local government jurisdiction must identify, as acceptable, the controller cabinet or system component(s) with an identification plate. The identification plate must be located inside the cabinet and may be attached with adhesive.
 - 8) Conductors of different circuits in same cable, enclosure or raceway. All traffic management system circuits will be permitted to occupy the same cable, enclosure, or raceway without regard to voltage characteristics, provided all conductors are insulated for the maximum voltage of any conductor in the cable, enclosure, or raceway.
- O. **Testing.** Electrical work shall be tested as required in this code. Tests shall be performed by the permit holder and observed by the Code Official.
- 1) **Apparatus, material and labor for tests.** Apparatus, material and labor required for testing an electrical system or part thereof shall be furnished by the permit holder.

- 2) **Reinspection and testing.** Where any work or installation does not pass an initial test or inspection, the necessary corrections shall be made so as to achieve compliance with this code. The work or installation shall then be resubmitted to the Code Official for inspection and testing.

85.21 Service Utilities

- A. **Connection of service utilities.** No person shall make connections from a utility, source of energy, fuel or power to any building or system that is regulated by this code for which a permit is required, until approved by the Code Official.
- B. **Temporary connection.** The Code Official shall have the authority to authorize the temporary connection of the building or system to the utility source of energy, fuel or power.
- C. **Authority to disconnect service utilities.** The Code Official shall have the authority to authorize disconnection of utility services or energy sources to the building, structure or system regulated by this code in case of an emergency where it is necessary to eliminate an immediate hazard to life or property. The Code Official shall notify the serving utility and, wherever possible, the owner and occupant of the building, structure or service system of the decision to disconnect prior to taking such action. If not notified prior to disconnecting, the owner or occupant of the building, structure or service system shall be notified in writing as soon as practical thereafter.
- D. **Connection after order to disconnect.** A person shall not make utility service or energy source connections to systems regulated by this code, which have been disconnected or ordered to be disconnected by the Code Official, or the use of which has been ordered to be discontinued by the Code Official until the Code Official authorizes the reconnection and use of such systems.

85.23 Unsafe Systems and Equipment

- A. **Unsafe electrical systems.** An electrical system that is unsafe, constitutes a fire or health hazard, or is otherwise dangerous to human life, as regulated by this code, is hereby declared as an unsafe electrical system. Use of an electrical system regulated by this code constituting a hazard to health, safety or welfare by reason of inadequate maintenance, dilapidation, fire hazard, disaster, damage or abandonment is hereby declared an unsafe use. Such unsafe equipment and appliances are hereby declared to be a public nuisance and shall be abated by repair, rehabilitation, demolition or removal.
- B. **Authority to condemn electrical systems.** Wherever the Code Official determines that any electrical system, or portion thereof, regulated by this code has become

hazardous to life, health or property, the Code Official shall order in writing that such electrical systems either be removed or restored to a safe condition. A time limit for compliance with such order shall be specified in the written notice. A person shall not use or maintain a defective electrical system or equipment after receiving such notice. Where such electrical system is to be disconnected, written notice as prescribed in this code shall be given. In cases of immediate danger to life or property, such disconnection shall be made immediately without such notice.

- C. **Dangerous conditions.** Wherever the Code Official shall find in any structure or upon any premises dangerous or hazardous conditions or materials, the Code Official is authorized to order such dangerous conditions or materials to be removed or remedied in accordance with the provisions of this code.
- D. **Record.** The Code Official shall cause a report to be filed on an unsafe condition. The report shall state the occupancy of the structure and the nature of the unsafe condition.
- E. **Notice.** If an unsafe condition is found, the Code Official shall serve on the owner, agent or person in control of the structure, a written notice that describes the condition deemed unsafe and specifies the required repairs or improvements to be made to abate the unsafe condition, or that requires the unsafe condition to be removed within a stipulated time.
- F. **Method of service.** Such notice shall be deemed properly served if a copy thereof is: (a) delivered to the owner personally; or (b) sent by certified or registered mail addressed to the owner at the last known address with the return receipt requested. If the certified or registered letter is returned showing that the letter was not delivered, a copy thereof shall be posted in a conspicuous place in or about the structure affected by such notice. Service of such notice in the foregoing manner upon the owner's agent or upon the person responsible for the structure shall constitute service of notice upon the owner.

85.25 Violations

- A. **Unlawful acts.** It shall be unlawful for any person, firm or corporation to erect, construct, alter, extend, repair, move, remove, demolish or occupy any system or equipment regulated by this code, or causes same to be done, in conflict with or in violation of any of the provisions of this code.
- B. **Notice of Violation.** Where the Code Official finds any building, premises, vehicle, system or equipment that is in violation of this code, the Code Official is authorized to issue corrective orders.

- 1) **Notice.** Wherever the Code Official determines violations of this code or observes an apparent or actual violation of a provision of this code or other codes or ordinances under the Code Official's jurisdiction, the Code Official is authorized to prepare a written notice of violation describing the conditions deemed unsafe and, where compliance is not immediate, specifying a time for re- inspection. Such order shall direct the discontinuance of the illegal action or condition and the abatement of the violation.
 - 2) **Service.** Any order or notice issued pursuant to this code shall be served upon the owner, operator, occupant or other person responsible for the condition or violation, either by personal service, mail or by delivering the same to, and leaving it with, some person of responsibility upon the premises. For unattended or abandoned locations, a copy of such order or notice shall be posted on the premises in a conspicuous place at or near the entrance to such premises, and the order or notice shall be mailed by certified mail with return receipt requested or a certificate of mailing, to the last known address of the owner, occupant or both.
 - 3) **Compliance with orders and notices.** Orders and notices issued or served as provided by this code shall be complied with by the owner, operator, occupant or other person responsible for the condition or violation to which the order or notice pertains.
 - 4) **Failure to correct violations.** If the notice of violation is not complied with, the Code Official is authorized to request the legal counsel of the jurisdiction to institute the appropriate legal proceedings to restrain, correct or abate such violation or to require removal or termination of the unlawful occupancy of the structure in violation of the provisions of this code or of any order or direction made pursuant thereto.
 - 5) **Failure to comply.** Failure to comply with an abatement notice or other corrective notice issued by the Code Official shall result in each day that such violation continues being regarded as a new and separate offense.
 - 6) **Unauthorized tampering.** Signs, tags or seals posted or affixed by the Code Official shall not be mutilated, destroyed or tampered with or removed without authorization from the Code Official.
- C. **Penalties.** Any person who fails to comply with the provisions of this code or who fails to carry out an order made pursuant of this code or violates any condition attached to a permit, approval or certificate shall be subject to the penalties as prescribed by law. The imposition of the penalties herein described shall not prevent the legal officer of

the jurisdiction from instituting appropriate action to prevent unlawful construction or to restrain, correct or abate a violation; or to prevent illegal occupancy of a structure or premises; or to stop an illegal act, conduct of business or occupancy of a structure on or about any premises.

- D. **Stop work order.** Upon notice from the Code Official that any electrical work is being done contrary to the provisions of this code or in a dangerous or unsafe manner, such work shall immediately cease. Such notice shall be in writing and shall be given to the owner of the property, or to the owner's agent, or to the person doing the work. The notice shall state the conditions under which work is authorized to resume.
- 1) Where an emergency exists, the Code Official shall not be required to give a written notice prior to stopping the work.
 - 2) Any person who shall continue any work in or about the structure after having been served with a stop work order, except such work as that person is directed to perform to remove a violation or unsafe condition, shall be subject to penalties as prescribed by law.

85.27 Means of Appeal

A person shall have the right to appeal a decision of the Code Official. An application for appeal shall be based on a claim that the true intent of this code or the rules legally adopted hereunder, have been incorrectly interpreted, the provisions of this code do not fully apply, or an equally good or better form of construction is proposed.

Appeals shall be heard by the hearing examiner pursuant to the applicable Chapters of the City's Municipal Code.

85.29 Additional Electrical Provisions

- A. All identified electrical hazards shall be abated. All identified hazardous electrical conditions in permanent wiring shall be brought to the attention of the Code Official responsible for enforcement of this code. Electrical wiring, devices, appliances and other equipment which is modified or damaged and constitutes an electrical shock or fire hazard shall not be used.
- B. Electrical appliances and fixtures shall be tested and listed in published reports of inspected electrical equipment by an approved agency and installed in accordance with all instructions included as part of such listing.
- C. The cutting, notching and boring of wood and steel framing members, structural members and engineered wood products shall be in accordance with the International Building Code.

- D. Penetrations of walls, floors, ceilings and assemblies required to have a fire-resistance rating, shall be protected in accordance with the International Building Code. Where cables, conductors and raceways penetrate fire blocking or draft stopping, such penetrations shall be protected by filling the annular space with an approved fire blocking material.
- E. Where appliances requiring access are installed in attics or underfloor spaces, a luminaire controlled by a switch located at the required passageway opening to such space and a receptacle outlet shall be provided at or near the appliance location.
- F. Emergency and standby power systems required by the International Building Code or International Fire Code shall be installed in accordance with the International Building Code, the International Fire Code, NFPA 110, NFPA 111 and this code.
- G. Smoke control systems required by the International Building Code or International Fire Code shall be supplied with two sources of power. Primary power shall be the normal building power systems. Secondary power shall be from an approved standby source complying with this code. The standby power source and its transfer switches shall be in a separate room from the normal power transformers and switch gear, and shall be enclosed in a room constructed of not less than 1-hour fire-resistance-rated fire barriers, ventilated directly to and from the exterior. Power distribution from the two sources shall be by independent routes. Transfer to full standby power shall be automatic and within 60 seconds of failure of the primary power.
- H. Elements of the smoke management system relying on volatile memories or the like shall be supplied with uninterruptable power sources of sufficient duration to span 15-minute primary power interruption. Elements of the smoke management system susceptible to power surges shall be suitably protected by conditioners, suppressors or other approved means.
- I. In addition to meeting the requirements of this code, all signal and control wiring for smoke control systems, regardless of voltage, shall be fully enclosed within continuous raceways.
- J. Combustible electrical or electronic wiring methods and materials, optical fiber cable, and optical fiber raceway exposed within plenums regulated by Section 602 of the International Mechanical Code shall have a peak optical density not greater than 0.50, an average optical density not greater than 0.15, and a flame spread not greater than 5 feet (1524 mm) when tested in accordance with NFPA 262. Only type OFNP (plenum-rated non-conductive optical fiber cable) shall be installed in plenum-rated optical fiber raceways. Wiring, cable and raceways addressed in this section shall be listed and

labeled as plenum rated and shall be installed in accordance with this code.

- K. Combustible electrical equipment exposed within plenums regulated by Section 602 of the International Mechanical Code shall have a peak rate of heat release not greater than 100 kilowatts (kW), a peak optical density not greater than 0.50, and an average optical density not greater than 0.15 when tested in accordance with UL 2043. Combustible electrical equipment shall be listed and labeled.
- L. Permanently installed equipment and appliances powered by internal combustion engines and turbines shall be installed in accordance with the manufacturer's installation instructions, the International Mechanical Code, International Fuel Gas Code and NFPA 37.
- M. Stationary fuel cell power systems having a power output not exceeding 10Mw shall be tested in accordance with ANSI CSA America FC1 and shall be installed in accordance with the manufacturer's installation instructions and NFPA 853.
- N. The power supply to the electrical control system for boilers shall be from a two-wire branch circuit that has a grounded conductor or from an isolation transformer with a two-wire secondary. Where an isolation transformer is provided, one conductor of the secondary winding shall be grounded. Control voltage shall not exceed 150 volts nominal, line to line. Control and limit devices shall interrupt the ungrounded side of the circuit. A means of manually disconnecting the control circuit shall be provided, and controls shall be arranged so that when de-energized, the burner shall be inoperative. Such disconnecting means shall be capable of being locked in the off position and shall be provided with ready access.
- O. Doors into electrical control panel rooms shall be marked with a plainly visible and legible sign stating ELECTRICAL ROOM or similar approved wording. The disconnecting means for each service, feeder or branch circuit originating on a switchboard or panelboard shall be legibly and durably marked to indicate its purpose unless such purpose is clearly evident.
- P. In new construction, required smoke alarms shall receive their primary power from the building wiring where such wiring is served from a commercial source and shall be equipped with a battery backup. Smoke alarms shall emit a signal when the batteries are low. Wiring shall be permanent and without a disconnecting switch other than as required for overcurrent protection.

Exception: Smoke alarms are not required to be equipped with battery backup in Group R-1 where they are connected to an emergency electrical system.

- Q. Where more than one smoke alarm is required to be installed within an individual dwelling unit or sleeping unit in Group R-2, R-3 or R-4, or within an individual sleeping unit in Group R-1, the smoke alarms shall be interconnected in such a manner that the activation of one alarm will activate all of the alarms in the individual unit. The alarm shall be clearly audible in all bedrooms over background noise levels with all intervening doors closed.
- R. Existing buildings. This section shall apply to existing buildings and structures that are within the scope of an adopted property maintenance code, abatement of dangerous buildings code, existing building code and/or housing code. Every occupied building shall be provided with an electrical system in compliance with the following requirements:
- 1) **Service.** The size and usage of appliances and equipment shall serve as a basis for determining the need for additional facilities in accordance with this code. Dwelling units shall be served by a threewire, 120/240 volt, single-phase electrical service having a rating of not less than 60 amperes.
 - 2) **Electrical system hazards.** Where it is found that the electrical system in a structure constitutes a hazard to the occupants or the structure by reason of inadequate service, improper fusing, insufficient receptacle and lighting outlets, improper wiring or installation, deterioration or damage, or for similar reasons, the Code Official shall require the defects to be corrected to eliminate the hazard.
 - 3) **Installation.** All electrical equipment, wiring and appliances shall be properly installed and maintained in a safe and approved manner.
 - 4) **Receptacles.** Every habitable space in a dwelling shall be provided with at least two separate and remote receptacle outlets. Every laundry area shall be provided with at least one grounding- type receptacle outlet or a receptacle outlet with ground fault circuit interrupter protection. Every bathroom shall contain at least one receptacle outlet. Any new bathroom receptacle outlet shall have ground fault circuit interrupter protection.
 - 5) **Luminaires.** Every public hall, interior stairway, toilet room, kitchen, bathroom, laundry room, boiler room and furnace room shall be provided with at least one electric luminaire.

Part 3–NEC Amendments

90.7 Examination of Equipment for Safety

Article 90.7 of the National Electrical Code is amended to read as follows:

90.7 Examination of Equipment for Safety. For specific items of equipment and materials referred to in this Code, examinations for safety made under standard conditions, to a recognized United States or harmonized international standard, provide a basis for approval where the record is made generally available through promulgation by organizations properly equipped and qualified for experimental testing, inspections of the run of goods at factories, and service-value determination through field inspections. This avoids the necessity for repetition of examinations by different examiners, frequently with inadequate facilities for such work, and the confusion that would result from conflicting reports on the suitability of devices and materials examined for a given purpose.

It is the intent of this Code that factory-installed internal wiring or the construction of equipment need not be inspected at the time of installation of the equipment, except to detect alterations or damage, if the equipment has been listed by a qualified electrical testing laboratory that is recognized as having the facilities described in the preceding paragraph and that requires suitability for installation in accordance with this Code.

100 Definitions

Article 100 of the National Electrical Code is amended and supplemented by the addition of the following definitions to read as follows:

“Accessible (as applied to wiring methods)” means capable of being removed or exposed without damaging the building structure or finish or not permanently closed in by the structure or finish of the building including insulation.

“Accessible, Readily (Readily Accessible)” means capable of being reached quickly for operation, renewal, or inspections without requiring those to whom ready access is requisite to climb over or remove obstacles or to resort to portable ladders, and so forth. In addition, it means that except for keys, no tools or other devices are necessary to gain access (e.g. covers secured with screws, etc.)

“Adult Residential Rehabilitation Center” means a residence, place, or facility designed or organized primarily to provide twenty-four-hour residential care, crisis and short-term care or long-term individualized active treatment and rehabilitation for clients diagnosed or evaluated as psychiatrically impaired or chronically mentally ill as defined herein or in chapter 71.24 RCW.

“Alcoholism Treatment Facility” means a private place or establishment, other than a licensed hospital, operated primarily for the treatment of alcoholism.

“Ambulatory Surgical Facility” means a facility, not a part of a hospital, providing surgical treatment to patients not requiring inpatient care in a hospital. This term does not include a facility in the offices of private physicians or dentists, whether for individual or group practice, if the privilege of using such facility is not extended to physicians or dentists outside the individual or group practice.

“Amusement Structure” means electrical or mechanical devices or combinations of devices operated for revenue and to provide amusement or entertainment to viewers or audiences at carnivals, fairs, or amusement parks. “Amusement structure” also means a bungee jumping device regardless of where located. “Amusement structure” does not include games in which a member of the public must perform an act, nor concessions at which customers may make purchases.

“Amusement Ride” means any vehicle, boat, bungee jumping device, or other mechanical device moving upon or within a structure, along cables or rails, through the air by centrifugal force or otherwise, or across water, that is used to convey one or more individuals for amusement, entertainment, diversion, or recreation. “Amusement ride” includes, but is not limited to, devices commonly known as sky rides, ferris wheels, carousels, parachute towers, tunnels of love, bungee jumping devices, and roller coasters.

“Amusement ride” does not include:

- a) Conveyances for persons in recreational winter sports activities such as ski lifts, ski tows, j-bars, t-bars, and similar devices subject to regulation under chapter 70.88 RCW;
- b) any single-passenger coin-operated ride that is manually, mechanically, or electrically operated and customarily placed in a public location and that does not normally require the supervision or services of an operator;
- c) non-mechanized playground equipment, including but not limited to, swings, seesaws, stationary spring-mounted animal features, rider-propelled merry-go-rounds, climbers, slides, trampolines, and physical fitness devices; or
- d) water slides.

“Approved Agency” means an established and recognized agency regularly engaged in conducting tests or furnishing inspection services, where the agency has been approved by the Code Official.

“Basement” means that portion of a building that is partly or completely below grade plane. A basement shall be considered as a story above grade plane and not a basement where the finished surface of the floor above the basement is:

- a) More than 6 feet above grade plane.
- b) More than 6 feet above the finished ground level for more than 50 percent of the total building perimeter; or
- c) More than 12 feet above the finished ground level at any point.

“Birth Center” or “Childbirth Center” means a type of maternity home which is a house, building, or equivalent organized to provide facilities and staff to support a birth service provided that the birth service is limited to low-risk maternal clients during the intrapartum period.

“Boarding Home” means any home or other institution, however named, which is advertised, announced, or maintained for the express or implied purpose of providing board and domiciliary care to seven or more aged persons not related by blood or marriage to the operator. It must not include any home, institution, or section thereof which is otherwise licensed and regulated under the provisions of state law providing specifically for the licensing and regulation of such home, institution, or section thereof.

“Building” is a structure that stands alone or that is separated from adjoining structures by a minimum two hour rated fire walls, and protected openings complying with the provisions of Section 705 of the International Building Code. The extent and location of such fire walls shall provide a complete separation.

“Certified Electrical Product” means an electrical product to which a laboratory, accredited by the State of Washington, has the laboratory’s certification mark attached.

“Certification Mark” is a specified laboratory label, symbol, or other identifying mark that indicates the manufacturer produced the product in compliance with appropriate standards or that the product has been tested for specific end uses.

“City” means the City that adopts and enforces this code.

“Code Official” means the person(s) or other designated authority charged with the administration and enforcement of this code, or a duly authorized representative.

“CWSTP” (Cable, Wire and Service Termination Policy) – reference to telecom) is the policy of the Federal Communications Commission (FCC) and the Washington utilities and transportation commission (WUTC) prescribed by tariff that governs negotiations between building owners and telecommunications service providers regarding the configuration of

POP(s) and demarcation point(s) in multitenant buildings when a MPOE policy is not elected by the telecommunications service provider.

“Educational Facility” refers to a building or portion of a building used primarily for educational purposes by six or more persons at one time for twelve hours per week or four hours in any one day. Educational facility includes: Schools (preschool through grade twelve), colleges, academies, universities, and trade schools.

“Egress, Unobstructed” (as it applies to NEC 110.26(C)(2)(a)) means having a clear egress path that allows a worker to travel to the exit from any other area in the room containing the equipment described in NEC 110.26(C)(2) without having to pass laterally or otherwise through that equipment’s required working space.

“Electrical Equipment” includes electrical conductors, conduit, raceway, apparatus, materials, components, and other electrical equipment not exempted by RCW 19.28.006(9). Any conduit/raceway of a type listed for electrical use is considered to be electrical equipment even if no wiring is installed in the conduit/raceway at the time of the conduit/raceway installation.

“Electrical Products Certification Laboratory” is a laboratory or firm accredited by the state of Washington to perform certification of electrical products.

“Electrical Products Evaluation Laboratory” is a laboratory or firm accredited by the state of Washington to perform on-site field evaluation of electrical products for safety.

“Enhanced Services Facility” is a Facility, or a portion of a facility, that provides treatment and services to persons for whom acute inpatient treatment is not medically necessary and who have been determined by Department of Social and Health Services

“Family Child Day Care Home” means the same as “family child care home” and “a child day care facility” licensed by the state, located in the family abode of the person or persons under whose direct care and supervision the child is placed, for the care of twelve or fewer children, including children who reside at the home. Electrical plan review is not required.

“Field Evaluated” means an electrical product to which a field evaluation mark is attached. Field evaluation shall include job site inspection unless waived by the department, and may include component sampling and/or laboratory testing.

“Field Evaluation Mark” is a specified laboratory label, symbol, or other identifying mark indicating the manufacturer produced the product in essential compliance with appropriate standards or that the product has been evaluated for specific end uses.

“Fished Wiring” is when cable or conduit is installed within the finished surfaces of an

existing building or building structure (e.g., wall, floor or ceiling cavity).

“Group Care Facility” means a facility other than a foster-family home maintained or operated for the care of a group of children on a twenty-four hour basis.

“Health or Personal Care Facility” – Health or personal care facility refers to buildings or parts of buildings that contain, but are not limited to, facilities that are required to be licensed by the department of social and health services or the department of health (e.g., hospitals, nursing homes, private alcoholism hospitals, private psychiatric hospitals, boarding homes, alcoholism treatment facilities, maternity homes, birth centers or childbirth centers, residential treatment facilities for psychiatrically impaired children and youths, and renal hemodialysis clinics) and medical, dental, or chiropractic offices or clinics, outpatient or ambulatory surgical clinics, and such other health care occupancies where patients who may be unable to provide for their own needs and safety without the assistance of another person are treated.

“High-Rise Building” is a building having occupied floors located more than 75 feet above the lowest level of fire department vehicle access.

Exception: The following buildings and structures as defined in the International Building Code shall not be considered as a high-rise building:

- a) Airport traffic control towers in accordance with IBC Section 412.
- b) Open parking garages in accordance with IBC Section 406.3.
- c) Buildings with an occupancy in Group A-5 in accordance with IBC Section 303.1
- d) Low-Hazard special industrial occupancies in accordance with IBC Section 503.1.2.
- e) Buildings with an occupancy in Group H-1, H-2 or H-3 in accordance with IBC Section 415.

“Hospital” means any institution, place, building, or agency providing accommodations, facilities, and services over a continuous period of twenty- four hours or more, for observation, diagnosis, or care of two or more individuals not related to the operator who are suffering from illness, injury, deformity, abnormality, or from any other condition for which obstetrical, medical, or surgical services would be appropriate for care or diagnosis.

“Hospice Care Center” means any building, facility, place, or equivalent, organized, maintained, or operated specifically to provide beds, accommodations, facilities, or services over a continuous period of twenty- four hours or more for palliative care of two or more individuals, not related to the operator, who are diagnosed as being in the latter stages of an advanced disease which is expected to lead to death.

“IBC” means the International Building Code.

“Identification Plate” is a phenolic or metallic plate or other similar material engraved in block letters at least ¼ inch high unless specifically required to be larger by this chapter, suitable for the environment and application. The letters and the background shall be in contrasting colors. Screws, rivets, permanent adhesive, or methods specifically described in this chapter shall be used to affix an identification plate to the equipment or enclosure.

“Industrial Control Panel” means a factory or user wired assembly of industrial control equipment such as motor controllers, switches, relays, power supplies, computers, cathode ray tubes, transducers, and auxiliary devices used in the manufacturing process to control industrial utilization equipment. The panel may include disconnecting means and motor branch circuit protective devices. Industrial control panels include only those used in a manufacturing process in a food processing or industrial plant.

“Installation” includes the act of installing, connecting, repairing, modifying, or otherwise performing work on an electrical system, component, equipment, or wire except as exempted by WAC 296-46B-925.

“Institutional Facility” refers to a building or portion of a building used primarily for detention and correctional occupancies where some degree of restraint or security is required for a time period of twenty-four or more hours. Such occupancies include, but are not restricted to: Penal institutions, reformatories, jails, detention centers, correctional centers, and residential- restrained care.

“Labeled” means an electrical product that bears a certification mark issued by a laboratory accredited by the state of Washington.

“Laboratory” may be either an electrical product(s) certification laboratory or an electrical product(s) evaluation laboratory.

“Like-in-kind” means having similar characteristics such as voltage requirement, current draw, circuit overcurrent and short circuit characteristics, and function within the system. Like-in-kind also includes any equipment component authorized by the manufacturer as a suitable component replacement part.

“Listed” means equipment has been listed and identified by a laboratory approved by the State of Washington for the appropriate equipment standard per this chapter.

“Low Voltage” means:

- a) NEC, Class 1 power limited circuits at 30 volts maximum.

- b) NEC, Class 2 circuits powered by a Class 2 power supply as defined in NEC 725.121(A).
- c) NEC, Class 3 circuits powered by a Class 3 power supply as defined in NEC 725.121(A).
- d) Circuits of Telecommunications systems as defined in chapter 19.28 RCW.

“Maternity Home” means any home, place, hospital, or institution in which facilities are maintained for the care of four or more women, not related by blood or marriage to the operator, during pregnancy or during or within ten days after delivery: provided, however, that this definition will not apply to any hospital approved by the American College of Surgeons, American Osteopathic Association or its successor.

“Medical, Dental, and Chiropractic Clinic” means any clinic or physicians’ office where patients are not regularly kept as bed patients for twenty-four hours or more.

“Mezzanine” is the intermediate level or levels between the floor and ceiling of any story with an aggregate floor area of not more than one-third of the area of the room or space in which the level or levels are located.

Also see “basement” and “story.”

“MPOE (Minimum Point of Entry – Telecom Reference)” is a building wiring policy of the FCC and WUTC for multitenant environment locations that can be elected by telecommunications service providers. It prescribes that the telecommunications service provider will provide a single POP for access to its network and is located either at the closest practicable point to where a telecommunications service provider’s facilities (fiber, coax, or copper) cross a property line or at the closest practicable point to where the wiring enters a multiunit building or buildings. All demarcations provided for customers and end-users by the provider will be placed within twelve inches of that POP.

“NEC” means National Electrical Code. Copies of the NEC are available from the National Fire Protection Association.

“NRTL” means Nationally Recognized Testing Laboratory accredited by the federal Occupational Safety and Health Administration (OSHA) after meeting the requirements of 29 CFR 1910.7.

“Nursing Home,” “Nursing Home Unit” or “Long-term Care Unit” means a group of beds for the accommodation of patients who, because of chronic illness or physical infirmities, require skilled nursing care and related medical services but are not acutely ill and not in need of the highly technical or specialized services ordinarily a part of hospital care.

“Occupancy” means the purpose for which a building, or part thereof, is utilized or occupied as defined by the International Building Code.

“Point of Contact” for utility work, means the point at which a customer’s electrical system connects to the serving utility system.

“POP” (Point-of-Presence – Telecom Reference), also called a “POT (point-of-termination),” is a designated point at or near a customer premise at which a telecommunications service provider’s facilities for the provision of access service ends. This can be a fiber, coax, or copper connection point.

Depending on the telecommunications service provider’s CWSTP with the individual building owner, demarcations may be established at the POP or at other designated locations. When the customer of a telecommunications service provider is another carrier, the demarcation will be at the closest POP to the end-user. A telecommunications service provider may have multiple POPs within a multiple tenant environment.

“Private Alcoholism Hospital” means an institution, facility, building, or equivalent designed, organized, maintained, or operated to provide diagnosis, treatment, and care of individuals demonstrating signs or symptoms of alcoholism, including the complications of associated substance use and other medical diseases that can be appropriately treated and cared for in the facility and providing accommodations, medical services, or other necessary services over a continuous period of twenty-four hours or more for two or more individuals unrelated to the operator, provided that this chapter will not apply to any facility, agency, or other entity which is owned and operated by a public or governmental body.

“Private Psychiatric Hospital” means a privately owned and operated establishment or institution which: provides accommodations and services over a continuous period of twenty-four hours or more, and is expressly and exclusively for observing, diagnosing, or caring for two or more individuals with signs or symptoms of mental illness who are not related to the licensee.

“Renal Hemodialysis Clinic” means a facility in a building or part of a building which is approved to furnish the full spectrum of diagnostic, therapeutic, or rehabilitative services required for the care of renal dialysis patients (including inpatient dialysis furnished directly or under arrangement). (NEC; Ambulatory Health Care Center)

“Residential Treatment Facility” means a facility licensed and operated twenty-four hours per day to provide health care to persons receiving services for a mental disorder or substance abuse.

“Residential Treatment Facility for Psychiatrically Impaired Children and Youth” means a residence, place, or facility designed or organized to provide twenty-four-hour residential care or long-term individualized, active treatment for clients who have been diagnosed or evaluated as psychiatrically impaired.

“Stand-alone Amplified Sound or Public Address System” is a system that has distinct wiring and equipment for audio signal generation, recording, processing, amplification, and reproduction. This definition does not apply to telecommunications installations.

“Story” is that portion of a building included between the upper surface of a floor and the upper surface of the floor or roof next above. Next above means vertically and not necessarily directly above. Also see “basement” and “mezzanine.”

“Structure” for the purposes of this chapter and in addition to the definition in the NEC, means something constructed either in the field or factory that is used or intended for supporting or sheltering any use or occupancy as defined by the IBC.

“Telecommunications Installations” is as described in RCW 19.28.400 for both regulated carriers and unregulated local service providers.

“Telecommunications Local Service Provider” is a regulated or unregulated (e.g., by the Federal Communications Commission or the utilities and transportation commission as a telephone or telecommunications provider) firm providing telecommunications service ahead of the telecommunications network demarcation point to an end user’s facilities.

“Telecommunications Network Demarcation Point” as defined in RCW 19.28.400 means the point or interconnection between the service provider’s communications cabling, terminal equipment, and protective apparatus and the customer’s premises telecommunications cabling system. The location of this point for regulated carriers is determined by federal and state regulations and is applicable for both regulated carriers and unregulated local service providers... The carrier should be contacted to determine the location policies in effect in the area.

“Utility” means electrical utility.

“Utility System” means electrical equipment owned by or under the control of a serving utility that is used for the transmission or distribution of electricity from the source of supply to the point of contact and is further defined as installations under the exclusive control of electric utilities for the purpose of communication, transmission, and distribution of electric energy located in buildings used exclusively by utilities for such purposes or located outdoors on property owned or leased by the utilities or on public highways, streets, roads, etc., or outdoors by established rights on private property.

It is the intent that this chapter covers all premises' wiring or wiring other than utility owned metering equipment, on the load side of the service point of buildings, structures, or any other premises not owned or leased by the utility. Also, it is the intent that this chapter covers installations in buildings used by the utility for purposes other than listed in the previous paragraph, such as offices buildings, warehouses, garages, machine shops, and recreational buildings which are not an integral part of a generating plant, substation, or control center.

“Utilization Voltage” means the voltage level employed by the utility's customer for connection to lighting fixtures, motors, heaters, or other electrically operated equipment other than power transformers.

110.2 Approval

Article 110.2 of the National Electrical Code is amended and supplemented by the addition of the following text to the end of Article 110.2:

All materials, devices, appliances and equipment not exempted in state law chapter 19.28. RCW, must conform to applicable standards recognized by the authority having jurisdiction, be listed, or field evaluated by an accredited electrical product testing laboratory. Equipment must not be energized until such standards are met, unless specific permission has been granted by the authority having jurisdiction.

110.3 Examination, Identification, Installation, Use and Listing (Product Certification) of Equipment

Article 110.3 of the National Electrical Code is amended and supplemented by the addition of a new subsection to be known as subsection 110.3(D), to read as follows:

(D) Industrial Control Panels and Utilization Equipment. Control panels and utilization equipment installed in industrial plants will be determined to meet the minimum electrical safety standards for installations by one of the following methods:

- 1) Listing and Labeling by an accredited electrical product testing laboratory.
- 2) Field evaluation by an accredited electrical product testing laboratory;
 - a) If the equipment usage is changed to other than industrial utilization equipment or electrical modifications are made to the equipment, the equipment must be successfully listed or field evaluated by an accredited electrical product testing laboratory.
 - b) The equipment must be permanently installed at the owner's facility and inspected per the requirements of this Chapter.

Use of industrial control panel(s) or equipment before its evaluation or final inspection, must be authorized by the Code Official or designated representative prior to its being energized.

Article 110.3 of the National Electrical Code is amended and supplemented by the addition of a new subsection to be known as subsection 110.3(E) to read as follows:

(E) Listed electrical conduit can only be installed and used in accordance with its listing (i.e., as an electrical raceway for electrical conductors). If used as a sleeve for electrical conductors or other listed electrical conduits, the installation of a listed electrical conduit will be assumed to be for use as an electrical raceway and must be installed as allowed by chapter 19.28 RCW and this chapter (e.g., owner exemption, electrical contractor, etc.).

110.11 Deteriorating Agents

Article 110.11 of the National Electrical Code is amended and supplemented by the addition of a new subsection to be known as subsection 110.11(A), to read as follows:

- A. **Electrical Equipment Submerged or Exposed to Water.** Electrical equipment and wiring that has been submerged or exposed to water must comply with the following:
- 1) All wire or cable listed for dry locations, molded-case breakers, fuses, electronic/solid state controllers, receptacles, lighting switches/dimmers, electric heaters, and any sealed device/equipment (e.g. relays, contactors, and similar equipment listed in NEMA 2006 publication titled "Evaluating Water Damaged Equipment") must be replaced.
 - 2) All other electrical equipment (e.g. wiring, breaker panelboards, disconnect enclosed switches, switchgear, motor control centers, boiler controls, HVAC/R equipment, electric motors, transformers, appliances, water heaters, and similar equipment listed in NEMA 2006 publication titled "Evaluating Water Damaged Equipment") may after consultation with and approval of the manufacturer, be reconditioned by properly trained personnel. The potential to recondition the equipment may vary with the nature of the electrical function, the degree of flooding, the age of the equipment, and the length of time the equipment was exposed to water.
 - 3) Before any electrical equipment is reconditioned and placed back into service, documentation shall be provided to the Code Official that the original manufacturer has reviewed and approved the reconditioning method, and that any recommended tests have been performed.

110.12 Mechanical Execution of Work

Article 110.12 of the National Electrical Code is amended and supplemented by the addition of new subsections to be known as 110.12(D), and 110.12(E), to read as follows:

(D) Abandoned Conductors and Cables. Electrical conductors or cables shall not be abandoned in place. Unused electrical conductors, or cables, regardless of voltage, and communication cables not in use shall be removed from the building or structure back to the originating panel board unless otherwise authorized by the authority having jurisdiction.

(E) Old, Used or Damaged Material and Equipment. Old, used or damaged electrical equipment, conductors or materials shall not be reinstalled or used in any new work without prior approval of the authority having jurisdiction.

110.16 Arc-Flash Hazard Warning

Article 110.16 of the National Electrical Code is amended and supplemented by the addition of the following text to the end of the first paragraph, to read as follows:

The flash protection marking shall be an identification plate or label meeting ANSI Standards Z535.4-1998 or be of a type approved by the Code Official or designated representative. The plate or label may be installed at the factory or in the field. The plate or label may be mounted using adhesive. The plate or label shall include all of the following:

- 1) The date of the flash hazard analysis.
- 2) The flash hazard category.
- 3) The incident energy level in cal/cm² at 18 inches from the flash hazard.
- 4) The flash hazard boundary.
- 5) The personal protective equipment that people within the Flash Hazard Boundary shall use.

The arc flash hazard shall be updated when a major modification, renovation or changes in the electrical distribution system that could affect the results of the arc flash hazard analysis takes place.

The arc flash hazard analysis shall take into consideration the design of the overcurrent protective device and its opening time, including its condition of maintenance.

110.22 Identification of Disconnecting Means

Article 110.22 of the National Electrical Code is further amended and supplemented by the addition of two new subsections to be known as subsection (D) and (E) to read as follows:

(D) The markings referenced in this section must be in the form of an identification plate or label in letters at least ½-inch high.

(E) Emergency disconnects and rapid shutdown initiating devices required by 230.85, 445.18(D), 480.7(B), and 690.12, shall be installed in close proximity to each other unless it is impracticable to do so, in which case a permanent identification plate which is red in color with white lettering shall be placed at each disconnect or initiating device location that identifies all other such locations on the building.

110.30 General

Article 110.30 of the National Electrical Code is amended and supplemented by the addition of new text following the original text to read as follows:

Each cable operating at over 1000 volts and installed on customer-owned systems must be legibly marked in a permanent manner at each termination point and at each point the cable is accessible. The required marking must use phase designation, operating voltage, and circuit number if applicable.

210.8 Ground Fault Circuit-Interrupter Protection for Personnel

Article 210.8(A) of the National Electrical Code is amended and supplemented by the addition of the following text to read as follows:

Exception: In a garage or unfinished basement, a red receptacle, with a red cover plate, supplying a fire alarm system is not required to have ground-fault circuit-interrupter protection. The receptacle must be identified for use only with the fire alarm system by an identification plate or cover with letters at least ¼ inch high.

Article 210.8(B) of the National Electrical Code is amended and supplemented by the addition of the following text to read as follows:

Exception: GFCI protection for personnel will not be required for:

- a) Three-phase receptacles unless specifically required elsewhere in the NEC; or
- b) Receptacles other than 125-volt, single phase, 15- or 20 ampere used for recreational vehicle supply equipment or for attachment of a mobile home supply cord.

Article 210.8(B)(2) of the National Electrical Code is amended and supplemented by the addition of the following text following the first paragraph to read as follows:

For the purposes of NEC 210.8(B)(2), kitchen means any area where utensils, dishes, etc., are cleaned or where food or beverages are prepared or cooked.

210.11 Branch Circuits Required

Article 210.11 of the National Electrical Code is amended and supplemented by the addition of a new subsection to be known as subsection 210.11(C)(5), to read as follows:

(5) Unfinished Spaces. In addition to the number of branch circuits required by other parts of this section, an additional raceway system or one dedicated 15 ampere minimum, 120 volt branch circuit shall be provided for unfinished spaces areas adaptable to future dwelling unit living areas that are not readily accessible to the service or branch circuit panelboard. One circuit or raceway is required for each 480 square feet or less of unfinished space area. If the total adjacent unfinished space area is less than 480 square feet, the circuit can be an extension of an existing circuit. The circuits must terminate in a suitable box(es). The box must contain an identification of the intended purpose of the circuit(s). The branch circuit panelboard must have adequate space and capacity for the intended load(s).

210.70 Lighting Outlets Required

Article 210.70 of the National Electrical Code is amended and supplemented by the addition of a new subsection to be known as subsection 210.70(C)(1) as follows:

210.70 Lighting Outlets Required

(C) All Occupancies

(1) Stairways and Landings. At least one lighting outlet shall be installed to illuminate all exterior stairways and landings.

215.10 Ground-Fault Protection of Equipment

Article 215.10 of the National Electrical Code is amended and supplemented by the addition of a new paragraph following the first paragraph of Article 215.10 to read as follows:

Equipment ground fault protection systems shall be performance tested prior to being placed into service to verify proper installation and operation of the system as determined by the manufacturer's published instructions. This test or a subsequent test shall include all system feeders. A firm having qualified personnel and proper equipment must perform the tests required. A copy of the manufacturer's performance testing instructions and a written performance acceptance test record signed by the person performing the test must be provided for the inspector's records at the time of inspection. The performance acceptance test record shall include test details including, but not limited to all trip settings and measurements taken during the test. The equipment being tested shall be labeled identifying the date of the test, the firm performing the test, and all settings for the equipment tested.

220.12 Lighting Loads for Specified occupancies

Article 220.12 of National Electrical Code is amended and supplemented by the addition of an exception to read as follows:

Exception: In determining feeder and service entrance conductor sizes and equipment ratings, the currently adopted Washington State Energy Code unit lighting power allowance table and footnotes may be used in lieu of NEC 220.12. The requirements of NEC 220.12(B), items 1, 2, and 3 do not apply.

220.87 Optional Calculations for Determining Existing Loads

Article 220.87 of National Electrical Code is amended and supplemented by the addition of the following text to the end of Subsection (1), Exception, to read as follows:

In addition to the 30-day demand data, the following information must be provided:

- a) The date of the measurements.
- b) A statement attesting to the validity of the demand data, signed by a registered professional engineer or the electrical administrator of the electrical contractor performing the measurements.
- c) A diagram of the electrical system identifying the point(s) of the measurements.

225.19 Clearances from Buildings for Conductors of Not over 1000 Volts, Nominal

Article 225.19 of the National Electrical Code is amended and supplemented by the addition of a new exception following the Exception No. 4: of Article 225.19(A) to read as follows:

Exception No. 5: Where the voltage between conductors does not exceed 300 and the roof area is guarded or isolated, a reduction in clearance to 3 feet shall be permitted.

225.32 Location

Article 225.32 of the National Electrical Code is amended and supplemented by the addition of a new paragraph following the first paragraph of Article 225.32 to read as follows:

Feeder disconnects, panelboards, subpanels, and similar electrical equipment must be installed so that they are readily accessible and may not be installed in bathrooms, clothes closets, or shower rooms. All indoor feeder disconnects, panelboards and subpanels and similar electrical equipment must have adequate working space and be adequately illuminated.

Article 225.32 of the National Electrical Code is further amended and supplemented by the addition of new subsections to be known as Subsection 225.32(1) and 225.32(2), to read as follows:

- 1) **Outside Locations:** A feeder disconnecting means required by NEC 700, 701 or 702 for a generator, is considered on the building if installed on the outside of the building or structure or within sight and within fifteen feet of the building or structure. All other feeder disconnecting means installed outside of a building or structure must be on the building or structure supplied. The building disconnecting means may supply only 1 building or structure unless the secondary building(s) or structure(s) has a separate building disconnecting means meeting the requirements of this subsection. The disconnecting means must have an identification plate with at least ½ inch high letters identifying:
 - a) The building or structure served; and
 - b) Its function as the building or structure main disconnect(s).
- 2) **Inside Location:** Where the feeder disconnecting means is installed inside the building or structure, it must be located so that the feeder raceway or cable extends no more than 15 feet inside the building or structure.

230.28 Service Mast as Support

Article 230.28 of the National Electrical Code is amended and supplemented by the addition of new text and drawings to the end of the first paragraph to read as follows:

Where a raceway-type service mast is used as support for service-drop conductors, the following conditions must be met:

- 1) Raceway type service mast shall be a minimum of 2-inch rigid metal conduit.
- 2) An approved roof flashing shall be installed on each mast where it passes through a roof. Plastic, non-hardening mastic shall be placed between lead-type flashings and the conduit. Approved neoprene type roof flashings may be permitted.
- 3) Masts shall be braced, secured, and supported in such a manner that no pressure from the attached conductors will be exerted on a roof flashing, meter base, or other enclosures.
- 4) Utilization of couplings for a mast shall not be permitted above the point the mast is braced, secured, or supported. There must be a minimum of two means of support above any couplings used. A properly installed cable or stiff leg type support qualifies as one of the two required means of support.
- 5) Except as otherwise required by the serving utility, service mast support guys shall be installed if the service drop attaches to the mast more than 24 inches above the roof line or if the service drop is greater than 100 feet in length from the pole or support. Masts for support of other than service drops shall comply with this requirement as well.
- 6) Intermediate support masts shall be installed in an approved manner with methods identical or equal to those required for service masts.
- 7) For altered services, where it is impractical to install U bolt mast supports due to interior walls remaining closed, it may be permissible to use other alternate mast support methods such as heavy gauge, galvanized, electrical channel.

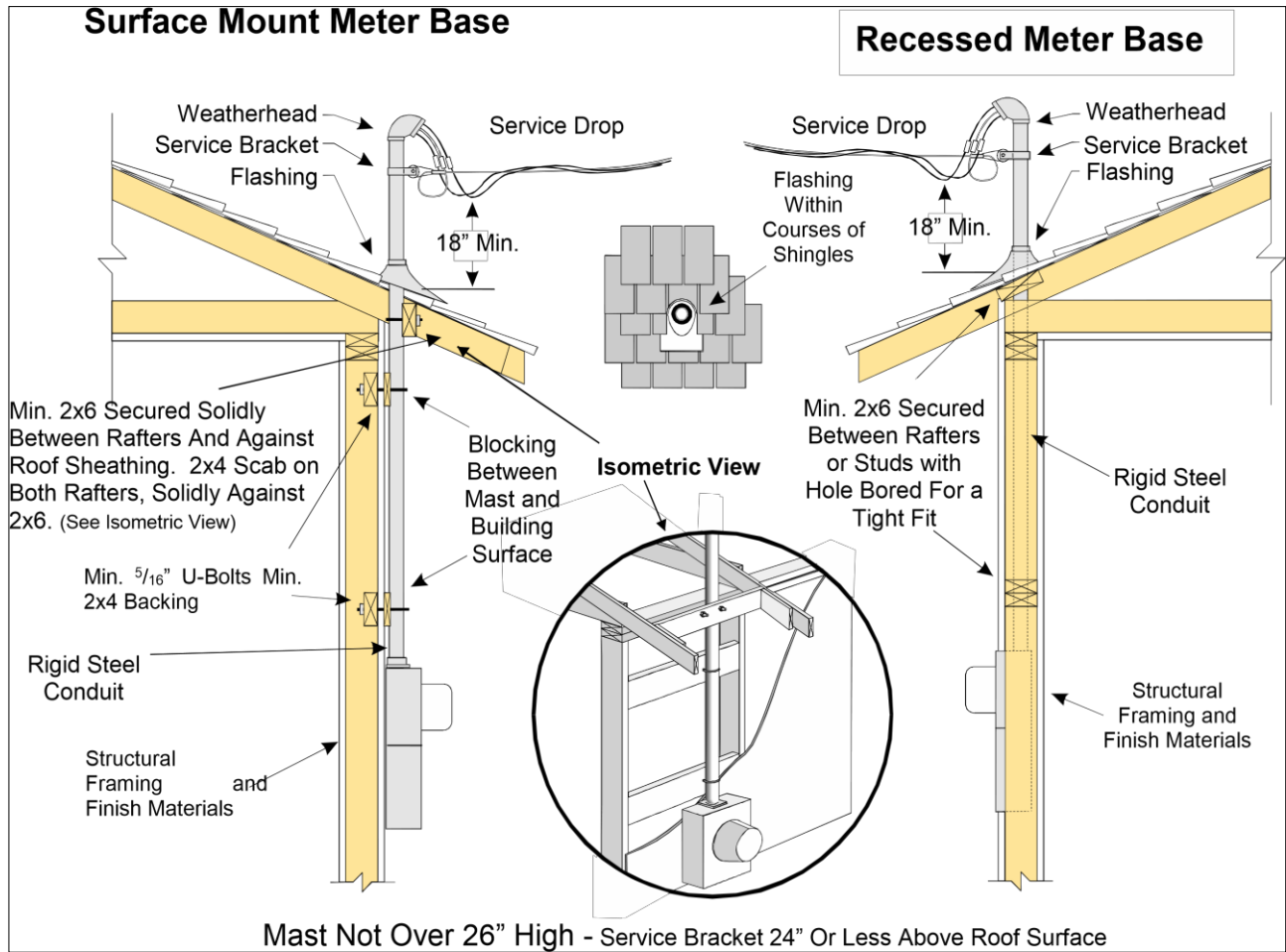

Service Mast Installation Details - Drawing E-101

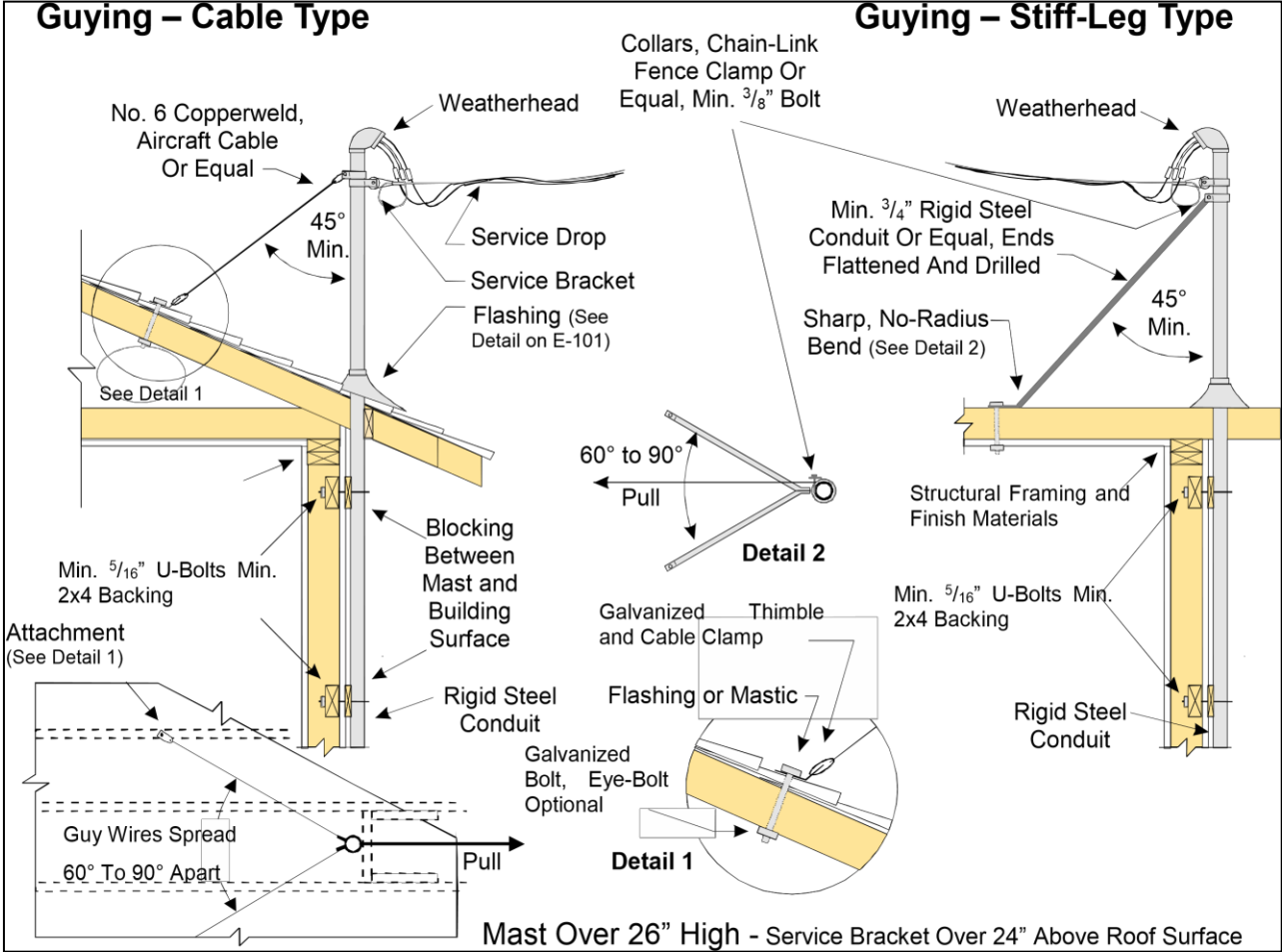

Service Mast Installation Details - Drawing E-102

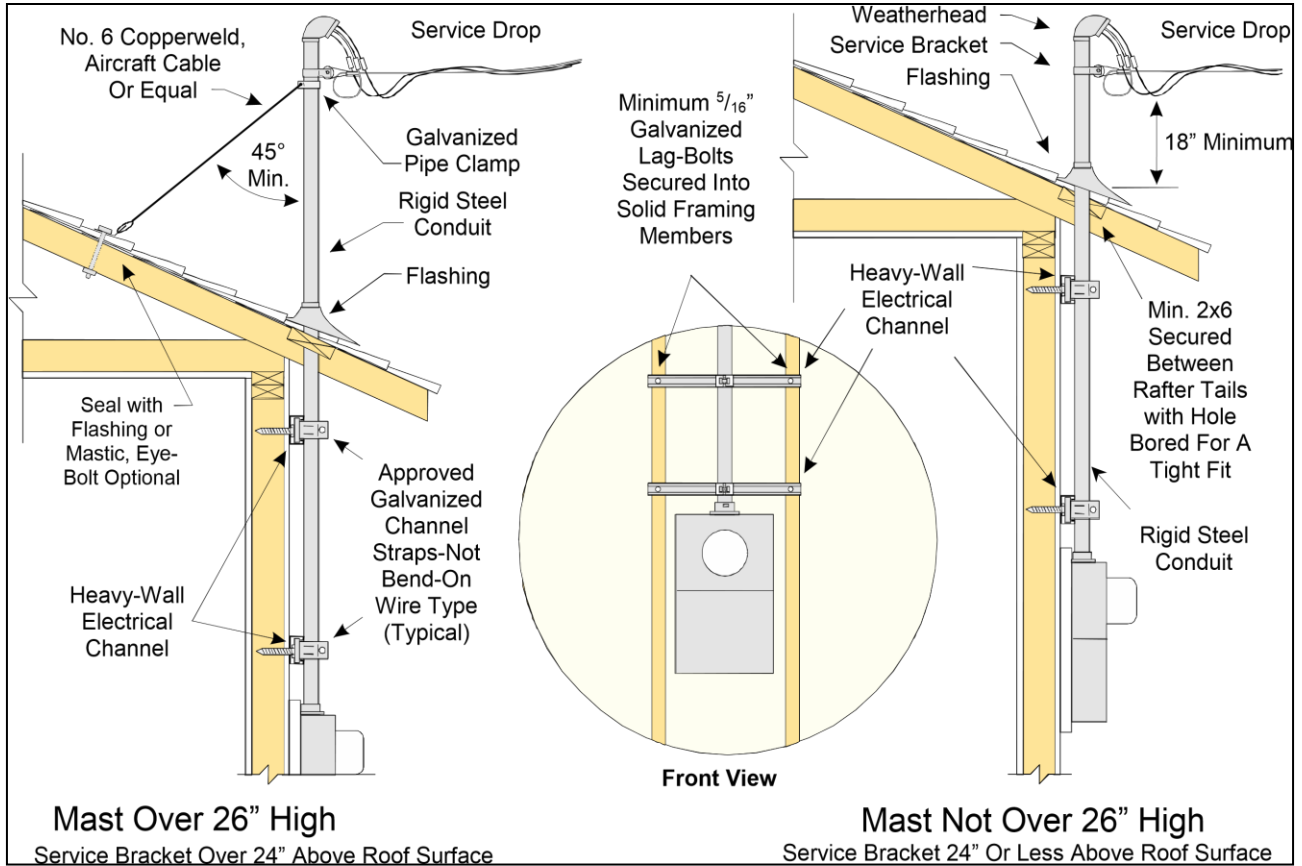

Service Mast Installation Details - Drawing E-103

230.43 Wiring Methods for 1000 Volts, Nominal, or Less

Article 230.43 of the National Electrical Code is amended to read as follows:

Service entrance conductors shall be installed in accordance with the applicable requirements of this code covering the type of wiring method used and shall be limited to the following methods:

- 1) Rigid metal conduit
- 2) Intermediate metal conduit
- 3) Wireways
- 4) Panelboards
- 5) Busways
- 6) Auxiliary gutters
- 7) Minimum schedule 40 Rigid polyvinyl chloride (PVC) conduit
- 8) Cablebus
- 9) Mineral-insulated, metal-sheathed cable (type MI).

Exception: With the approval of the authority having jurisdiction existing electrical metallic tubing used for service entrance conductors may be permitted to remain, provided it meets all of the following conditions:

- 1) It was installed prior to October 1984
- 2) It is properly grounded
- 3) The conduit is installed in a non-accessible location
- 4) It is the proper size for the installed conductors

230.70 Service Equipment-Disconnecting Means-General

Subsection 230.70(A)(1) of the National Electrical Code is amended and supplemented by the addition of new Subsections (a) and (b) to read as follows:

- 1) Outside Location. The service disconnect means shall be installed on the building or structure it serves. The service disconnection means shall be labeled with a plate with ½ inch letters providing the following information:
 - 2) The building or structure served; and
 - 3) Its function as the building or structure main service disconnect(s).
- 4) Inside Location. Where the service disconnect is installed inside the building or structure, it shall be located so that the service raceway extends no more than 15 feet inside the building or structure served. Service disconnecting means, panel boards, subpanels and similar electrical equipment shall be adequately illuminated.

Subsection 230.70(A)(3) of the National Electrical Code is amended to read as follows:

(3) Bathrooms, Clothes Closets, Toilet Rooms and Shower Rooms. Service disconnection means, panel boards, subpanels and similar electrical equipment shall not be installed in bathrooms, clothes closets, toilet rooms or shower rooms.

230.90 Service Equipment-Overcurrent Protection

Exception No. 3 to Article 230.90(A) of the National Electrical Code is amended to read as follows:

Exception No. 3: Two to six circuit breakers or sets of fuses shall be permitted as the overcurrent device to provide the overload protection. The sum of the ratings of the circuit breakers or fuses shall be permitted to exceed the ampacity of the service conductors, provided the calculated load does not exceed the ampacity of the service conductors. Where the service conductors have a lesser ampacity than the overcurrent protection or the equipment rating that they terminate in or on, an identification plate with ½ inch letters, showing the ampacity of the conductors must be installed on the service equipment and stating: "Allowable ampacity of the service conductors is: Amps".

230.95 Ground Fault Protection of Equipment

Article 230.95 of the National Electrical Code is amended and supplemented by the addition of a new paragraph following the first paragraph to read as follows:

Equipment ground fault protection systems shall be performance tested prior to being placed into service to verify proper installation and operation of the system as determined by the manufacturer's published instructions. This test or a subsequent test shall include all system feeders. A firm having qualified personnel and proper equipment must perform the tests required. A copy of the manufacturer's performance testing instructions and a written performance acceptance test record signed by the person performing the test must be provided for the inspector's records at the time of inspection. The performance acceptance test record shall include test details including, but not limited to all trip settings and measurements taken during the test. The equipment being tested shall be labeled identifying the date of the test, the firm performing the test, and all settings for the equipment tested.

230.202 Services Exceeding 1000 Volts Service-Entrance Conductors

Subsection 230.202(B) of the National Electrical Code is amended and supplemented by the addition of new text to the end of the Subsection to read as follows:

Wiring methods for service conductors exceeding 1000 volts, nominal, within a building or structure are limited to the following methods:

- 1) Rigid metal conduit
- 2) Intermediate metal conduit
- 3) Busways
- 4) Minimum schedule 80 Rigid polyvinyl chloride (PVC) conduit
- 5) Cablebus; metal-clad cable that is exposed for its entire length

240.24 Overcurrent Protection-Location in or on Premises

Article 240.24 (C) of the National Electrical code is amended and supplemented by the addition of a paragraph and conditions following the original paragraph to read as follows:

- 1) Where the NEC or manufacturer's instructions do not specify minimum height requirements for equipment enclosures, enclosures containing an overcurrent device(s) shall be installed so that the bottom of the enclosure containing the overcurrent device(s) is not less than 24 inches above finished grade unless:
 - a) The equipment enclosure or listed equipment on which the enclosure is mounted is approved for pad-, floor-, ground-, dock-, or pier-mounting; or
 - b) The equipment enclosure is located over:
 - i. Concrete or asphalt paving that extends 3 or more feet horizontally from the surface of the enclosure; or
 - ii. Roofs

Article 240.24 (F) of the National Electrical Code is amended and supplemented by the addition of an exception to Article 240.24 (F) to read as follows:

Exception: If the overcurrent device is a part of a panelboard that is being repaired or replaced in an existing location, the installation is allowed to be made above the stairs.

250.28 Main Bonding Jumper and System Bonding Jumper

Article 250.28 (D)(3) of the National Electrical Code is amended to read as follows:

(3) Separately Derived System with More than One Enclosure. Where a separately derived system supplies more than a single enclosure, the system bonding jumper for each enclosure shall be sized in accordance with 250.28 (D) (1) based on the largest ungrounded feeder/tap conductor serving that enclosure, or a single system bonding jumper shall be installed at the source and sized in accordance with 250.28 (D) (1) based on the equivalent size of the largest supply conductor determined by the largest sum of the areas of the corresponding conductors of each set.

250.50 Grounding Electrode System

Article 250.50 of the National Electrical Code is amended and supplemented by the addition of a new Subsection (1) to read as follows:

(1) At each new building or structure served, a concrete-encased grounding electrode complying with NEC 250.52(A)(3) shall be installed. All electrodes shall be inspected prior to covering, concealing or the placing of concrete.

Exception: New buildings or structures, job site construction trailers, mobile/manufactured homes where not installed on a permanent concrete foundation.

250.53 Grounding Electrode System Installation

Article 250.53 of the National Electrical Code is amended and supplemented by the addition of new text following the first Exception of Article 250.53(A)(2) to read as follows:

Exception: A temporary construction service is not required to have more than one rod or pipe electrode.

250.64(B) Grounding Electrode Conductor Installation

Article 250.64(B) of the National Electrical Code is amended and supplemented by the addition of new text to following 250.64(B)(4) to read as follows:

- 4) Grounding electrode conductors will be considered not exposed to physical damage when the conductor(s) are:
 - a) Buried more than 12 inches deep in the earth outside the building's footprint;
 - b) Encased or covered by 2 inches of concrete or asphalt;
 - c) Located inside the building footprint and protected by the building's structural elements or when inside and determined, by the inspector, to not be subject to physical damage; or
 - d) Enclosed by a metal or nonmetallic raceway or enclosure. The raceway or enclosure must be approved to protect from severe physical damage if it is not protected by appropriate physical barriers from contact with vehicles, lawn mowers, and other equipment that might damage the conductor or enclosure.

250.104(A) Bonding of Piping Systems and Exposed Structural Steel

Article 250.104(A)(1) of the National Electrical Code is amended and supplemented by the addition of new Subsections (5) and (6) to read as follows:

(5) Bonding Hot and Cold Plumbing Pipes. The hot and cold plumbing pipes shall be bonded together. Hot and cold metallic plumbing lines are considered to be bonded together if, at the time of inspection, the inspector can determine that the lines are mechanically and electrically joined by one or more mixing valves.

(6) Metallic Stubs or Valves. Metallic stubs or valves used in nonmetallic plumbing systems are not required to be bonded to the electrical system unless required by the equipment manufacturer's instructions.

250.104(B) Other Metal Piping

Article 250.104 of the National Electrical Code is amended and supplemented by the addition of new Subsection (6) and to read as follows:

(6) The bonding conductor or jumper for gas piping systems must be a minimum 6 AWG copper and terminate at an accessible location on the load side of the gas meter on either a solid iron gas pipe or a cast flexible gas piping fitting using a listed grounding connector.

250.184(A) Solidly Grounded Neutral Systems

Article 250.184(A) of the National Electrical Code is amended and supplemented by the addition of new Subsections (3) and (4) to read as follows:

3) Existing Installations.

- a) The use of a concentric shield will be allowed for use as a neutral conductor for extension, replacement, or repair, if all of the following are complied with:
 - i. The existing system uses the concentric shield as a neutral conductor;
 - ii. Each individual conductor contains a separate concentric shield sized to no less than 33 ½ percent of the ampacity of the phase conductor for 3-phase systems or 100 percent of the ampacity of the phase conductor for single-phase systems;
 - iii. The new or replacement cable's concentric shield is enclosed inside an outer insulating jacket; and
 - iv. Existing cable (i.e. existing cable installed directly in the circuit between the work and the circuit's overcurrent device) successfully passes the following tests:

- a) A cable maintenance high potential dielectric test. The test must be performed in accordance with the cable manufacturer's instruction or the 2019 ANSI/NETA maintenance test specifications.
- b) A resistance test of the cable shield. Resistance must be based on the type, size, and length of the conductor used as the cable shield using the conductor properties described in NEC Table 8 Conductor Properties.
- c) A registered professional engineer must provide a specific certification to the authority having jurisdiction or designated representative in writing that the test results of the maintenance high
- d) potential dielectric test and the resistance test have been reviewed by the electrical engineer and that the cable shield is appropriate for the installation.
- e) The registered engineer must stamp the certification document with the engineer's stamp and signature. The document may be in the form of a letter or electrical plans. Testing results are valid for a period of seven years from the date of testing. Cable will not be required to be tested at a shorter interval.
- v. A concentric shield used as a neutral conductor in a multi-grounded system fulfills the requirements of an equipment grounding conductor.
- vi. Where a separate conductor is used as the neutral for an extension, replacement, or repair, the conductor must pass a resistance test. Resistance must be based on the type, size, and length of the conductor used as the cable shield using the conductor properties described in NEC Table 8 Conductor Properties.

b) New Installations.

- i. New installations shall not include extensions of existing circuits.
- ii. The use of the concentric shield will not be allowed for use as a neutral conductor for new installations. A listed separate neutral conductor meeting the requirements of NEC 250.184(A) must be installed.

300.4 Protection Against Physical Damage

Section 300.4(A) of the National Electrical Code is supplemented to read as follows:

Exterior Shear Panel/Sheathing. The exterior shear panel/sheathing nail inspection must be completed by the Building Code Inspector and, where siding nails or fasteners which

penetrate into the wall cavity are to be used, all siding must be installed; or all wiring and device boxes must be a minimum of 2 ½ inches from the exterior surface of the framing member; or all wiring and device boxes must be protected by a steel plate a minimum of 1/16 inch thick and of appropriate width and height installed to cover the area of the wiring and/or box.

Table 300.5 Underground Installations

Table 300.5 of the National Electrical Code is supplemented by addition of a note following note 5.

Note 6. Where practicable raceways shall be installed beneath an interior slab.

300.11 Securing and Supporting

Section 300.11(A) of the National Electrical Code is amended to read as follows:

- A. **Secured in Place.** Raceways, cable assemblies, boxes, cabinets, and fittings shall be securely fastened in place. Where not restricted by the authority having jurisdiction or Article 300, raceways, cables, or boxes may be installed in suspended ceilings provided the installation complies with the following:
- 1) The support wires are independent of the ceiling support system.
 - 2) The support wires are a minimum #12 AWG and securely fastened to the structural ceiling and to the ceiling gridsystem.
 - 3) Cables and raceways shall not be supported by ceiling grids.
 - 4) Raceways and/or cables are not larger than ¾ inch trade size;
 - 5) No more than two raceways or cables are supported by a support wire.
 - a) The two-cable limitation does not apply to telecommunications cables, Class 2 cables, or Class 3 cables on support wires installed exclusively for such cables provided:
 - i) The support wire must be adequate to carry the cable(s) weight and all attached cables must be secured with approved fittings;
 - and ii) The maximum number of cables shall not be more than a 2-inch diameter when bundled together.
 - 6) Raceways and cables are secured to the support wires by fittings designed and manufactured for the purpose.
 - 7) The raceways or cables serve equipment that is located within the ceiling cavity or is mounted on or supported by the ceiling grid system.

- a) Telecommunications cables, Class 2 cables, or Class 3 cables supported as required by this section, may pass through ceiling cavities without serving equipment mounted on or supported by the ceiling grid system.
- 8) NEC power limited, Class 2, and Class 3 cables must be secured in compliance with Article 334.30 and must be secured to boxes in compliance with Article 314.17.
- 9) Telecommunications cables must be secured in a manner that will not cause damage to the cables and at intervals not exceeding five feet. Cables are considered adequately supported when run through holes in building structural elements or other supporting elements. Telecommunications cables may be fished into inaccessible hollow spaces of finished buildings. Clamps or fittings are not required where telecommunications cables enter boxes.
- 10) Optical fiber cables must be secured in a manner that will not cause damage to the cables and at intervals not exceeding five feet. Cables are considered adequately supported when run through holes in building structural elements or other supporting elements. Optical fiber cables may be fished into inaccessible hollow spaces of finished buildings. Supports must allow a bending radius that will not cause damage to the cables.

311.16 Marking

Article 311.16 of the National Electrical Code is amended and supplemented by the addition of a new subsection to be known as subsection 311.16(D), to read as follows:

(D) Required Marking. Each cable must be legibly marked in a permanent manner at each termination point and at each point the cable is accessible. The required marking must include phase designation, operating voltage, and circuit number if applicable.

312.8 Switch and Overcurrent Device Enclosures.

Article 312.8 of the National Electrical Code is amended and supplemented by the addition of a new subsection to be known as subsection 312.8(C), as follows:

312.8 Switch and Overcurrent Device Enclosures

(C) Live Parts

Where disconnecting means of systems above 30 volts are readily accessible to unqualified persons, any enclosure door or hinged cover that exposes live parts when open shall be locked or require a tool to open.

314.23 Supports

Section 314.23(H) of the National Electrical Code is amended to read as follows:

- H. **Pendant Boxes.** An enclosure supported by a pendant shall comply with 314.23(H)(1) or (H)(2). In addition, a pendant box suspended by a flexible cord, must not contain conduit "knockouts" and the connection to the suspended box must utilize an integral threaded hub.
- 1) **Flexible Cord.** A box supported from a flexible cord must comply with the following.
 - a) The maximum length of the cord for a suspended pendant drop from a permanently installed junction box to a suitable tension takeup device above the pendant box must not exceed six feet.
 - b) The flexible cord must be supported at each end with an approved cord grip or strain relief connector fitting/device that will eliminate all stress on the conductors and the conductor connections.
 - c) The flexible cord must be a minimum #14 AWG copper.
 - d) The flexible cord ampacity must be determined using NEC Table 400.5(A) column A.
 - e) The flexible cord must be hard or extra hard usage.
 - 2) **Conduit.** A box supporting lampholders or luminaires (lighting fixtures), or wiring enclosures within luminaires (fixtures) used in lieu of boxes in accordance with 300.15(B), shall be supported by rigid or intermediate metal conduit stems. For stems longer than 18 inches, the stems shall be connected to the wiring system with flexible fittings suitable for the location. At the luminaire (fixture) end, the conduit(s) shall be threaded wrench tight into the box or wiring enclosure, or into hubs identified for the purpose.

Where supported by only a single conduit, the threaded joints shall be prevented from loosening by the use of set-screws or other effective means, or the luminaire (fixture), at any point, shall be at least 8 feet above grade or standing area and at least 3 feet measured horizontally to the 8 feet elevation from windows, doors, porches, fire escapes, or similar locations. A luminaire (fixture) supported by a single conduit shall not exceed 12 inches in any horizontal direction from the point of conduit entry.

314.29 Boxes, Conduit Bodies and Handhole Enclosures to Be Accessible

Article 314.29 of the National Electrical Code is amended and supplemented by the addition the following text to read as follows:

Conduit bodies, junctions, pull, and outlet boxes must be installed so that the wiring contained in them is accessible without removing any part of the building structure, including insulation material.

334.10 Nonmetallic-Sheathed Cables: Types NM, NMC, and NMS-Uses Permitted

Article 334.10(1)(2)(3) and (4) of the National Electrical Code is amended to read as follows:

Uses Permitted. Type NM, Type NMC, and Type NMS cables shall be permitted to be used in the following, except as prohibited in 334.12:

- 1) One and two-family dwellings and their attached or detached garages, and their storage buildings.
- 2) Multi-family dwellings permitted to be of Types III, IV-HT, and V construction.
- 3) Other structures permitted to be of Types III, IV-HT, and V construction.
- 4) Cable trays in structures permitted to be Types III, IV-HT, or V where the cables are identified for the use.

334.15 Exposed Work

Article 334.15 (C) is amended and supplemented by the addition of the following exception to read as follows:

Exception: The requirement for nonmetallic sheathed cable protection in this section does not apply in crawl spaces.

358.10(D) Electrical Metallic Tubing: Type EMT – Wet Locations

Article 358.10(D) of the National Electrical Code is amended and supplemented by the addition of a new paragraph following the first paragraph, to read as follows:

Where installed in wet locations, an equipment grounding conductor must be provided within the raceway and sized per NEC 250.122

358.12 Electrical Metallic Tubing: Type EMT - Uses Not Permitted

Article 358.12 of the National Electrical Code is amended and supplemented by the addition of a new subsection to be known as subsection 358.12(3), to read as follows:

(3) Installed in direct contact with the earth or in concrete on or below grade.

394.12 Concealed Knob-and-Tube Wiring - Uses Not Permitted

Article 394.12 of the National Electrical Code is amended and supplemented by the addition of a new Exception to Article 394.12(5), to read as follows:

Exception: Hollow spaces containing existing knob-and-tube wiring are allowed to be insulated provided that all of the following conditions are met:

- 1) The wiring shall be surveyed by an appropriately licensed electrical contractor who must certify in writing to the authority having jurisdiction that the wiring is in good condition with no evidence of improper overcurrent protection, conductor insulation failure or deterioration, and with no improper connections or splices. The electrical inspector must inspect all repairs, alterations, or extensions to the electrical system;
- 2) The insulation shall meet Class I specifications as identified in the International Building Code, with a flame spread factor of 25 or less as tested using ASTM E84-81a. Foam insulation may not be used with knob-and-tube wiring;
- 3) All knob-and-tube circuits shall have overcurrent protection in compliance with NEC Table 310.16, 60 degree centigrade, Column C. Overcurrent protection shall be circuit breakers or Type S fuses.

Article 404.3 of the National Electrical Code is amended and supplemented by the addition of a new subsection to be known as subsection 404.3 (C), as follows:

404.3 Enclosure

Article 404 of the National Electrical Code is amended and supplemented by the addition of a new subsection to be known as 404.3(C) to read as follows:

(C) Live Parts

Where disconnecting means of systems above 30 volts are readily accessible to unqualified persons, any enclosure door or hinged cover that exposes live parts when open shall be locked or require a tool to open.

406.12 Tamper Resistant Receptacles

Article 406 of the National Electrical Code is amended and supplemented by the addition of text to read as follows:

406.12(9) Tamper-Resistant Receptacles in Other Locations. Listed tamper-resistant receptacles are required in psychiatric patient care facilities where accessible to psychiatric patients

410.10 Bathtub and Shower Areas

Article 410.10(D) of the National Electrical Code is amended to read as follows:

(3) Bathtub and Shower Areas. All luminaires within an enclosed shower area or directly over a bathtub to a height of 8 feet above the water line, or within 5 feet of the water line in any direction must be enclosed, unless specifically listed for such use. These luminaires must be ground-fault circuit interrupter protected.

410.62 Cord Connected Lampholders and Luminaires

Article 410.62 of the National Electrical Code is amended and supplemented by the addition of a new subsection to be known as subsection 410.62(C)(1)(4), to read as follows:

- 4) A ground-type attachment plug cap and receptacle connection at the source junction box is not required when the flexible cord complies with NEC 410.30 and the following:
 - a) Connection to a source junction box must utilize an approved cable connector or clamp;
 - b) The flexible cord must be supported at each end with an approved cord grip or strain relief connector fitting/device that will eliminate all stress on the conductor connections;
 - c) The maximum length of the cord for a suspended pendant drop from a permanently installed junction box to a suitable tension take-up device above the pendant luminaire must not exceed 6 feet;
 - d) The flexible cord must be a minimum #14 AWG copper;
 - e) The flexible cord ampacity must be determined in NEC Table 400.5(A) column A;
 - f) The flexible cord must be hard or extra hard usage; and
 - g) A vertical flexible cord supplying electric discharge luminaires must be secured to the luminaire support as per NEC 334.30(A).

422.10 Appliances Branch-Circuit Rating

Article 422.10 of the National Electrical Code is amended and supplemented by the addition of a new paragraph at the end of Article 422.10(A), to read as follows:

Water heaters with a rated circuit load in excess of 3,500 watts, but less than 4900 watts, at 208 or 240 volts shall be provided with branch circuit conductors not smaller than #10 AWG copper or equal. Overcurrent protection shall comply with NEC 422.11.

430.7 Marking on Motors and Multimotor Equipment

Article 430.7 is amended and supplemented by the following text to be inserted following the title:

Except as required by the National Electrical Code, there is no requirement for motors to be identified for use or listed/field evaluated by a laboratory. All motors must be manufactured according to National Electrical Manufacture's Associations (NEMA) standard for motors except motors that:

- 1) Are a component part of equipment listed or field evaluated by a laboratory; or
- 2) Are a component part of industrial utilization equipment approved by the Department of L&I.

440.14 Air Conditioning and Refrigerating Equipment

Article 440.14 of the National Electrical Code is amended and supplemented by the addition of a third paragraph to follow the first and second paragraphs to read as follows:

In one- and two-family dwelling units, a disconnecting means is required for the indoor units(s) of a split system HVAC/R system, unless the outside unit's disconnecting means is: lockable, disconnects the indoor unit and an indoor disconnecting means is not required by the manufacturer.

450.27 Oil Insulated Transformers Installed Outdoors

Article 450.27 of the National Electrical Code is amended and supplemented by the addition of the following text to the end of the last paragraph of Article 450.27 to read as follows:

Oil-Insulated transformers located adjacent to building(s) or structures shall comply with the following:

- 1) Transformers shall not be located closer than 8 feet to any part of a building or structure constructed of combustible material including any eaves, overhangs or decks;
- 2) Transformers shall not be located closer than 2 feet to any part of a building or

structure constructed of non-combustible material including any eaves, overhangs or decks and must be outside a line extended vertically from the ends of the eaves, overhangs or rooflines of the building or structure;

- 3) Transformers shall not be located closer than 8 feet to any part of doors, windows, stairways, ventilation openings, other types of openings of all buildings or structures;
- 4) Transformers shall be located such that any oil leaking from the transformer will flow away from the building or structure and will not pool; and
- 5) Transformers located in areas subject to vehicular traffic shall be provided with adequate guarding.
- 6) Enclosures for total underground oil filled transformers shall not be located closer than 8 feet to any part of a doorway, window, stairway or fire escape. Adequate space must be maintained above the enclosure so that a boom may be used to lift the transformer from the enclosure.

450.42 Transformer Vaults - Walls, Roofs and Floors

Article 450.42 Exception of the National Electrical Code is amended and supplemented to read as follows:

Exception: Where transformers are protected with automatic sprinkler, water spray, carbon dioxide, or halon and installed five stories or less above finished grade, construction of 1-hour rating shall be permitted.

501.200 Sewage Disposal Systems

Article 501 of the National Electrical Code is amended and supplemented by the addition of a new Section 501.200, to read as follows:

- A Pumping chambers for sewage, effluent, or grinder pumps in on- site and septic tank effluent pump (S.T.E.P.) disposal systems will be considered unclassified when not more than five residential units are connected to the system, residential units are connected to a utility sewage system, or when nonresidential systems have residential loading characteristics and all of the following general installations requirements are complied with:
 - 1) The pumping chamber must be adequately vented. Venting may be accomplished through the building or structure plumbing vents where the system venting has been approved by the local jurisdiction authority or by a direct 2 inch minimum vent to the atmosphere;

- 2) Equipment that in normal operation may cause an arc or spark must not be installed in any pumping chamber;
 - 3) Float switches installed in a pumping chamber must be hermetically sealed to prevent the entrance of gases or vapors;
 - 4) Junction boxes, conduits and fittings installed in the septic atmosphere must be of a noncorrosive type, installed to prevent the entrance of gases or vapors;
 - 5) Where a conduit system is installed between the pumping chamber and the control panel, motor disconnect, or power source, an approved sealing method must be installed to prevent the migration of gases or vapors from the pumping chamber, must remain accessible;
 - 6) Wire splices in junction boxes installed in pumping chambers must be suitable for wet locations.
- B. Residential wastewater loading characteristics in a nonresidential installation:
- 1) For systems that process less than three thousand five hundred gallons of wastewater per day shall be certified by:
 - a) An on-site wastewater designer licensed under chapter 18.210 RCW; or
 - b) A professional engineer, engaged in the business of on-site wastewater system design, licensed under chapter 18.43 RCW.
 - 2) For systems that process three thousand five hundred gallons or more of wastewater per day may be certified by a professional engineer, engaged in the business of on-site wastewater system design, licensed under chapter 18.43 RCW. Written documentation must be signed and stamped by the designer or engineer and provided to the electrical inspector prior to inspection.
 - a) Any residential or nonresidential system that has building or structure floor drains being discharged into the system is classified as Class I Division I
 - 1) Drains from any commercially made tub, shower, basin, sink, or toilet are not considered floor drains.
 - b) Pumping chamber access covers can be covered by gravel, light aggregate, or non-cohesive granulated soil, and must be accessible for excavation. Access covers that are buried must have their exact location identified at the electrical panel or other prominent location by an identification plate. The authority having jurisdiction for performing electrical inspections must approve the identification plate location.

- c) Indoor grinder pumps installed in chambers with less than fifty gallons capacity are not required to meet the requirements of this section, except for the venting requirements in subsection (A)(1) of this section. Indoor grinder pumps installed in chambers with less than fifty gallons capacity are not classified systems as described in Article 500 NEC.
- d) Secondary treatment effluent pumping chambers such as sand filters are unclassified, and require no special wiring methods.
- e) Inspection approval is required prior to covering or concealing any portion of the septic electrical system, including the pump. New septic and effluent tanks containing electrical wires and equipment must be inspected and approved prior to being loaded with sewage.

514.3 Hazardous (Classified) Locations

Article 514.3(D)(2) of the National Electrical Code is amended and supplemented by deleting exception numbers 1 and 2 and adding new exception number 1 to read as follows:

Exception No. 1: Dock, pier, or wharf sections that do not support fuel dispensers and may abut a section(s) that supports a fuel dispenser(s) are permitted to be unclassified where documented air space between the sections is provided and where flammable liquids or vapors cannot travel to these sections. Documentation shall be provided as required in NEC 500.4(A).

514.11 Circuit Disconnects

Article 514.11 (A) of the National Electrical Code is amended and supplemented by the addition of the following subsections to be known as subsections 514.11 (A) (1), (2), and (3), to read as follows:

- 1) The disconnecting means shall disconnect all conductors of the circuit supplying all station dispensers and or pumps (including the grounded conductor) simultaneously from the source(s) of supply.
- 2) For multi-circuit installations, an electrically held normally open contactor operated by a push-button or other suitable device may serve as the disconnecting means. The push button or disconnecting device shall not function as the resetting mechanism for the electrically held contactor.

The resetting means shall meet the following:

- a) Located at least 15 feet or out of sight of the pushbutton; and
- b) Protected by a suitable cover or guard; and

- c) Identified with an approved identification plate that has white lettering on a black background.
- 3) The disconnecting means shall be labeled with an identification plate, with letters at least 1 inch high, as the emergency disconnecting means.

The disconnecting means or operator must be:

- a) Substantially red in color; and
- b) For attended facilities – Must be readily accessible and must be located outdoors and within sight of the pump or dispensing equipment it controls; or
- 4) For unattended facilities – must be readily accessible and must be located within sight, but at least 20 feet from the pump or dispensing equipment it controls.

517.28 Essential Electrical Systems for Hospitals

Article 517 of the National Electrical Code is amended and supplemented by the addition of a new section to be known as section 517.28, to read as follows:

517.28 General Requirements. In health care facilities, the following methods must be used to determine adequate capacity and ratings of equipment providing electrical power for the essential electrical systems.

A. Systems in New Facilities:

- 1) **Essential Electrical System:** The essential electrical system must consist of three branches known as:
 - a) **Life Safety Branch:** The feeder conductors and equipment used to supply electrical power to the life safety branch must be determined by summation of the connected loads as determined by Article 220 NEC and may not be subjected to any reduction due to the diversity of the loads. Feeder and equipment will be subject to a 125 percent multiplier for continuous loads in accordance with article 220 NEC.
 - b) **Critical Branch:** The feeder conductors and equipment must be calculated in accordance with article 220 NEC, including a level of diversity as determined by such article.
 - c) **Equipment Branch:** The feeder conductors and equipment used to supply electrical power to the equipment branch of the essential electrical system must be calculated in accordance with Article 220 NEC, including a level of diversity as determined by such article.

- 2) **Generator Sizing:** The rating of the generator(s) supplying electrical power to the essential system of a health care facility must meet or exceed the summation of the loads determined in and (b) of this subsection with no additional demand factors applied. Momentary X-ray loads may be ignored if the generator is rated at least 300 percent of the largest momentary X-ray load connected.

B. Existing Essential Systems in Facilities to Which Additional Load is to be Added:

- 1) **Existing Loads:** The existing loads of the separate branches of the essential electrical system may be determined by NEC Article 220.87(1).

If NEC 220.87(1) is used, the following is required:

- a) The date of the measurements.
 - b) A statement attesting to the validity of the demand data, signed by a professional electrical engineer or the electrical administrator of the electrical contractor performing the work.
 - c) A diagram of the electrical system identifying the point(s) of measurement.
 - d) Building demand measured continuously on the highest loaded phase of the feeder or service over a thirty-day period, with the demand peak clearly identified.
 - e) Demand peak is defined as the maximum average demand over a fifteen minute interval.
- 2) **Added Loads:** Added loads to the separate branches of the essential electrical system must be determined by subsection (a) of this section.
 - 3) **Generator Sizing:** The rating of the generator(s) supplying electrical power to the essential electrical system must meet or exceed the summation of the loads determined by (a) and (b) of this subsection with no additional demand factors applied.

519 Educational and Institutional Occupancies

The National Electrical Code is amended and supplemented by the addition of a new article to be known as **Article 519 – Educational and Institutional Occupancies** to read as follows:

Scope. This article covers educational and institutional occupancies as defined in the Article.

Wiring Methods. The wiring methods in educational or institutional occupancies shall be limited to metallic or nonmetallic raceways, MI, MC, or AC cable. Places of Assembly within an Educational or Institutional occupancy may not be wired according to Section 518.4(b) or (c).

Exception: Limited energy systems may use wiring methods in accordance with this Code.

525.1 Carnivals, Circuses, Fairs, and Similar Events - Scope

Article 525.1 of the National Electrical Code is amended to read as follows:

525.1 Scope. This article covers the installation of portable wiring and equipment for carnivals, circuses, fairs, and similar functions, including wiring in or on all structures. In addition to the requirements in this Article, all wiring and equipment for carnivals, circuses, fairs, and similar functions must also comply with WAC 296-403A.

547.1 Agricultural Buildings - Scope

Article 547.1 of the National Electrical Code is amended to read as follows:

547.1 Scope. The provisions of this article shall apply to the following agricultural buildings or that part of a building or adjacent areas of similar or like nature greater than 1,000 square feet and used as part of a business or commercial farming activity as specified in 547.1 (A) and (B).

555 Marinas, Boatyards, Floating Buildings, and Commercial and Noncommercial Docking Facilities

Article 555 of the National Electrical Code is amended and supplemented by the addition of the following text.

- 1) For the purposes of NEC 555.7, transformer terminations must be located a minimum of 12 inches above the deck of a dock (datum plane requirements do not apply for this section).
- 2) For the purposes of NEC 555.4, adjacent means within sight.
- 3) For the purposes of NEC 555.30, all electrical connections must be installed a minimum of 12 inches above the deck of a pier unless the connections are approved for wet

locations within junction boxes identified for wet locations, utilizing sealed wire connector systems listed and identified for submersion (datum plane requirements do not apply for this section).

- 4) For the purposes of NEC 555.31, all enclosures must be corrosion resistant. All gasketed enclosures must be arranged with a weep hole to discharge condensation.
- 5) For the purposes of NEC 555.32, gasketed enclosures are only required for wet locations.
- 6) For the purposes of NEC 555.34, the following wiring methods are allowed:
 - a) All wiring installed in a damp or wet location must be suitable for wet locations.
 - b) Extra-hard usage portable power cables rated not less than 75°C, 600 volts, listed for wet locations and sunlight resistance and having an outer jacket rated for the environment are permitted. Portable power cables are permitted as a permanent wiring method under or within docks and piers or where provided with physical protection. The requirements of NEC 555.34 (B)(3)(b) do not apply.
 - c) Overhead wiring must be installed at the perimeter of areas where boats are moored, stored, moved, or serviced to avoid possible contact with masts and other parts of boats. NEC Article 398 open wiring on insulators is not an approved wiring method in or above any portion of a marina or docking facility.
 - d) For the purposes of NEC 555.34 (B)(4), the wiring methods of Chapter 3 NEC will be permitted.
- 7) For the purposes of NEC 555.33, receptacles must be mounted not less than 12 inches above the deck surface of the pier or dock (datum plane requirements do not apply for this section). Shore power receptacles that provide shore power for boats must be rated not less than 20 amperes and must be single outlet type and must be of the locking and grounding type or pin and sleeve type.
- 8) Floating buildings.
- 9) Where shore power is provided, a disconnecting means must be located within sight of each floating building or similar facility. The disconnecting means must be installed adjacent to but not in or on the floating building or similar facility.
- 10) NEC 555.53 is amended to read: The overcurrent protective device(s) that supply the floating building shall have ground-fault protection not exceeding 30 mA.
- 11) Conductors operating in excess of 600 volts, nominal may not be installed on floating portions of a floating building or similar facility.

590.1 Temporary Installations - Scope

Article 590.1 of the National Electrical Code is amended and supplemented to read as follows:

590.1 Scope. The provisions of this article apply to temporary electrical power and lighting installations. For the purposes of this section, any circuit used for construction purposes is considered to be temporary.

590.4 Temporary Installations (General) - Splices

Article 590.4 of the National Electrical Code is amended by revising subsection 590.4(G) to read as follows:

(G) Splices. On construction sites, a splice or junction box is not required for splices or junction connections where splices of conductors are at least 10 feet above the grade or floor level and where not subject to contact from personnel.

600.3 Electrical Signs and Outline Lighting - Listing

Article 600.3 of the National Electrical Code is amended and supplemented by the addition of a new paragraph following the first paragraph, to read as follows:

All electrical signs and outline lighting regardless of voltage must be listed to the applicable ANSI UL Standard. Installation will be inspected for compliance and installation instructions and the NEC.

600.4 Electrical Signs and Outline Lighting - Markings

Article 600.4 of the national Electric Code is amended by adding new subsection 600.4(G) to read as follows:

In addition to the markings required by the NEC, retrofit signs and outline lighting shall be marked with a label made of a background color contrasting to the listed product in a location visible during servicing near the listed retro fit subassembly that states "This equipment contains a retrofit assembly that may present a risk of electrical hazard. Replace parts only with the same type and rating." The labels font must be Arial size 16 bold. This label may be an identification plate as described in Article 100 or an adhesive label approved by the inspector. This label is in addition to any labeling required by the manufacturer's instructions or the UL Standard used to manufacture the retrofit kit.

600.10 Portable or Mobile Signs

Article 600.10 (C) of the National Electrical Code is amended to read as follows:

(3) Receptacle Outlet. A weatherproof GFCI receptacle outlet that is weatherproof with the supply cord connected must be installed within 6 feet of each electrical sign. Extension cords are not permitted to supply portable outdoor signs.

600.21 Ballasts, Transformers, Class 2 Power Supplies and Electronic Power Supplies

Article 600.21 of the National Electrical Code is amended and supplemented by the addition of a new subsection (G), to read as follows:

(G) Outside Awnings. Luminaires installed in outdoor awnings shall be of a type that is suitable for wet locations and be connected by a wiring method suitable for wet locations. Fluorescent luminaires shall be installed so that no part of the luminaire is located closer than 6 inches to the awning fabric. Incandescent luminaires shall be installed so that no part of the luminaire is located closer than 18 inches to the awning fabric.

Luminaires installed in outside awnings shall be controlled by a disconnect installed in conformance with Article 600.6. Listed awning signs must be installed in compliance with the manufacturer's instructions and the NEC.

600.30 Electrical Signs and Outline Lighting - Applicability

Article 600.30 of the National Electrical Code is amended and supplemented by the addition of the following new text to follow the first paragraph to read as follows:

Field-installed skeleton tubing is not required to be listed. Installations will be inspected for compliance with the installation instructions and the NEC.

680.3 Swimming Pools, Fountains, and Similar Installations - Approval of Equipment

Article 680.3 of the National Electrical Code is amended and supplemented by the addition of the following Subsection (A) to follow the first paragraph, to read as follows:

(A) Electrical components which have failed and require replacement shall be replaced with identical products unless the replacement part is no longer available; in which case, a like-in-kind product may be substituted provided the mechanical and grounding integrity of the equipment is maintained.

680.15 Field Installed Equipment

Article 680 of the National Electrical Code is amended and supplemented by the addition of new Section to be known as Article 680.15 to read as follows:

680.15 Field Installed Equipment. Field installed electrical equipment for a swimming pool, hot tub, spa or swim spa shall not be located closer than 5 feet from inside wall of the swimming pool, hot tub, spa or swim spa. The 5 foot separation may be reduced by the installation of a permanent barrier, such as a solid wall, fixed glass windows or doors, etc. The 5 foot separation shall be determined by the shortest path or route that a cord can travel from the spa, hot tub, swim spa, or swimming pool to the equipment.

Field installed electrical equipment must meet the following additional requirements:

- 1) Heaters are listed as a "swimming pool heater or a spa heater";
- 2) Pumps are listed as a "swimming pool pump" or "spa pump" or "swimming pool/spa pump";
- 3) Other equipment such as panelboards, conduit, and wire are suitable for the environment and comply with the applicable codes.
- 4) The field assembly or installation of "recognized components" shall not be permitted.

680.40 Spas and Hot Tubs - General

Article 680.40 of the National Electrical Code is amended and supplemented by the addition of a new Subsection (A) and a new Subsection (B), to read as follows:

- A. **Modular, Self-Contained Spa or Hot Tubs.** Equipment assemblies for self-contained spas or hot tubs shall be installed within 5 feet from the inside wall of the spa or hot tub. Equipment assemblies shall be listed or field evaluated as a unit with the spa or hot tub.
- B. **Packaged Spa or Hot Tub Equipment Assemblies.** Equipment assemblies (skid pack) pre-packaged by a factory shall not be installed closer than 5 feet from the inside wall of the spa or hot tub and shall be listed as a package unit.

680.70 Hydromassage Bathtubs - General

Article 680.70 of the National Electrical Code is amended and supplemented by the addition of the following text to the end of the first paragraph, to read as follows:

Hydromassage bathtubs must be listed as a unit and bear a listing mark which reads "Hydromassage bathtub."

690.2 Solar Photovoltaic Systems - Definitions

Article 690.2 of the National Electrical Code is amended and supplemented by the addition of the following definitions, to read as follows:

Photovoltaic System. The photovoltaic system may conduct alternating current, direct current, or both and will comprise all interconnected circuits to the point of connection with the building distribution circuits or utility service conductors.

690.4 Solar Photovoltaic Systems – General Requirements

Article 690.4 of the National Electrical Code is amended and supplemented by the addition of a new subsection to be known as 690.4(E) and read as follows:

(E) Labels and Identification. Required “WARNING” labels as specified by NEC 690 are required to be an identification plate on or immediately adjacent to the pertinent equipment.

All photovoltaic circuits must be identified at each overcurrent protection device(s) and panel directory(ies).

690.7 Solar Photovoltaic Systems - Maximum Voltage

Article 690.7 of the National Electrical Code is amended and supplemented by replacing the second paragraph of Article 690.7(A) with the following text, to read as follows:

The open-circuit voltage temperature coefficients supplied in the instruction of listed photovoltaic modules will be used to determine the maximum direct current photovoltaic system voltage. Otherwise the voltage will be calculated using Table 690.7 of the National Electrical Code. For the purposes of this calculation, a temperature correction factor of 1.25 will be used unless another factor can be justified and is approved by the authority having jurisdiction.

700.5 Emergency Systems - Transfer Equipment

Article 700.5 of the National Electrical Code is amended and supplemented by the addition of a new subsection (F) to read as follows:

(F) Location. In high-rise buildings and underground buildings, per IBC 403 and 405 respectively, the emergency transfer switches where required by the IBC or this code shall be located in a separate room from the normal power source including transformers and distribution equipment and shall be enclosed in a room constructed of not less than 2-hour fire-resistive-rated fire barriers ventilated directly to and from the exterior. The emergency transfer switches, where required by the IBC or this code in other buildings or uses, shall be located in a separate room from the normal power source including transformers and distribution equipment and shall be enclosed in a room constructed of

not less than 1-hour fire-resistive-rated fire barriers ventilated directly to and from the exterior. Power distribution from the two sources to the emergency transfer switches shall be by independent routes. Independent routes shall mean either a minimum 1-hour fire-resistance separation, or a physical distance of not less than 50 feet.

Exception: System components described in Article 701 may occupy the same dedicated spaces as emergency systems.

700.7 Emergency Systems - Signs

Article 700.7 of the National Electrical Code is amended and supplemented by the addition of the following paragraph prior to subsection (A) to read as follows:

Signs required in this section must be placed at the service disconnecting means and the meter base if the service disconnecting means and meter base are not located within sight and within 5 feet of each other.

700.10 Wiring, Emergency Systems

Article 700.10 of the National Electrical Code is amended and supplemented by amending Article 700.10(A) and adding a new Article 700.10(E) to read as follows:

A. Identification.

- 1) **Emergency Systems.** All boxes and enclosures larger than 6 inches by 6 inches (including transfer switches, generators and power panels) for emergency circuits shall be permanently marked with an identification plate that is orange in color so they will be readily identified as a component of the emergency circuit or system. All other device and junction boxes for emergency systems and circuits shall be orange in color, both inside and outside.
- 2) **Smoke Control Systems.** All boxes and enclosures larger than 6 inches by 6 inches (including transfer switches, generators and power panels) for smoke control power and control circuits shall be permanently marked with an identification plate that is orange in color with a yellow diagonal stripe so they will be readily identified as a component of the smoke control circuit or system. All other device and junction boxes for smoke control systems and circuits shall be orange in color both inside and outside. Cover plates shall be orange in color with a yellow diagonal stripe.
- 3) **Stair and Elevator Pressurization Systems.** All boxes and enclosures larger than 6 inches by 6 inches (including transfer switches, generators and power panels) for stair and elevator pressurization system power and control circuits shall be permanently marked with an identification plate that is orange in color with a gray

diagonal stripe so they will be readily identified as a component of the stair and elevator pressurization system. Raceways for stair and elevator pressurization system wiring shall be identified by labels or color coding which distinguish it from all other systems and shall be visible at the time of inspection All other device and junction boxes for stair and elevator pressurization system power and control circuits shall be orange in color both inside and outside. Cover plates shall be orange in color with a gray diagonal stripe.

Exception: In existing facilities, the existing nameplate identification color scheme may be retained where approved by the Code Official.

700.10(E) Smoke Control Systems, Pressurization Wiring and Equipment

Where smoke control, stair pressurization and elevator pressurization is required by the City Building Code, all power and control wiring and equipment, including the emergency source of power and transfer switch(s) for smoke control, stair pressurization and elevator pressurization systems shall be installed in accordance with this Article (NEC 700-Emergency Systems), and all applicable sections of the IBC as amended and adopted by the City Building Code.

700.12 Emergency Systems - Sources of Power

Article 700.12 of the National Electrical Code is amended and supplemented by the addition of three new paragraphs following the last paragraph to read as follows:

In high-rise buildings and underground buildings, per IBC 403 and 405 respectively, the emergency source of power shall be located in a separate room from the normal power source including transformers and distribution equipment and shall be enclosed in a room constructed of not less than 2-hour fire-resistive-rated fire barriers ventilated directly to and from the exterior.

In other buildings or uses the emergency source of power, where required by the IBC or this code shall be located in a separate room from the normal power source including transformers and distribution equipment and shall be enclosed in a room constructed of not less than 1-hour fire resistive-rated fire barriers ventilated directly to and from the exterior.

Power distribution from the emergency source to the emergency transfer switch shall be by an independent route from the normal source.

Article 700.12(D)(5) of the National Electrical Code is amended and supplemented by the addition of new text following the first paragraph to read as follows:

A generator set located less than 10 feet from the building(s) shall be enclosed within an approved structure of 1-hour fire resistive construction. Where located more than 10 feet but less than 20 feet shall be within an approved enclosure.

700.32 Emergency Systems - Coordination

Article 700.32 of the National Electrical Code is amended and supplemented by the addition of a new exception #2 following the first exception to the first paragraph to read as follows:

Exception #2: The requirements for selective coordination described are not required where the emergency system was installed prior to June 1, 2006. For new emergency systems that are supplied from an existing emergency system installed prior to June 1, 2006, the new portion of the emergency system shall comply with NEC 700.32. The ground fault sensing function of overcurrent protective devices will only be required to selectively coordinate with the ground fault sensing functions of other overcurrent protective devices.

701.5 Legally Required Standby Systems - Transfer Equipment

Article 701.5 of the National Electrical Code is amended and supplemented by the addition of a new subsection (E) to read as follows:

(E) Location. In high-rise buildings the legally required standby source of power and its transfer switches shall be located in a separate room from the normal power source including transformers and distribution equipment and shall be enclosed in a room constructed of not less than 2-hour fire-resistive rated fire barriers ventilated directly to and from the exterior. Power distribution from the two sources shall be by independent routes.

Exception: System components described in Article 700 may occupy the same dedicated spaces as the legally required standby systems.

701.7 Legally Required Standby Systems - Signs

Article 701.7 of the National Electrical Code is amended and supplemented by the addition of the following paragraph prior to subsection (A) to read as follows:

Signs required in this section must be placed at the service disconnecting means and the meter base if the service disconnecting means and meter base are not located within sight and within 5 feet of each other.

701.10 Legally Required Standby Systems - Wiring Legally Required Standby Systems

Article 701.10 of the National Electrical Code is amended and supplemented by the addition of a new subsection (A) to read as follows:

A Identification.

- 1) **Smoke Control Systems.** All boxes and enclosures larger than 6 inches by 6 inches (including transfer switches, generators, and power panels) for smoke control power and control circuits shall be permanently marked with an identification plate that is orange in color with a yellow diagonal stripe and black numerals (701) so they will be readily identified as a component of the smoke control circuit or system. All other device and junction boxes for smoke control systems and circuits shall be orange in color both inside and outside. Cover plates shall be orange in color with a yellow diagonal stripe.
- 2) **Stair and Elevator Pressurization Systems.** All boxes and enclosures larger than 6 inches by 6 inches (including transfer switches, generators, and power panels) for stair and elevator pressurization system power and control circuits shall be permanently marked with an identification plate that is orange in color with a gray diagonal stripe and black numerals (701) so they will be readily identified as a component of the stair and elevator pressurization system. Raceways for stair and elevator pressurization system wiring shall be identified by labels or color coding which distinguish it from all other systems and shall be visible at the time of inspection All other device and junction boxes for stair and elevator pressurization system power and control circuits shall be orange in color both inside and outside. Cover plates shall be orange in color with a gray diagonal stripe.

Exception: In existing facilities, the existing nameplate identification color scheme may be retained where approved by the Code Official.

- 3) **Stair and Elevator Pressurization Systems.** All boxes and enclosures larger than 6 inches by 6 inches (including transfer switches, generators and power panels) for stair and elevator pressurization system power and control circuits shall be permanently marked with an identification plate that is orange in color with a gray diagonal stripe so they will be readily identified as a component of the stair and elevator pressurization system. Raceways for stair and elevator pressurization system wiring shall be identified by labels or color coding which distinguish it from all other systems and shall be visible at the time of inspection All other device and junction boxes for stair and elevator pressurization system power and control

circuits shall be orange in color both inside and outside. Cover plates shall be orange in color with a gray diagonal stripe.

Exception: In existing facilities, the existing nameplate identification color scheme may be retained where approved by the Code Official

701.12(B) Legally Required Standby Systems - Sources of Power

Article 701.12(B)(5) of the National Electrical Code is amended and supplemented by the addition of new text following the first paragraph to read as follows:

A generator set located less than 10 feet from the building(s) shall be enclosed within an approved structure of 1-hour fire resistive construction. Where located more than 10 feet but less than 20 feet shall be within an approved enclosure.

701.32 Legally Required Standby Systems – Selective Coordination

Article 701.32 of the National Electrical Code is amended and supplemented by the addition of a new exception following the first exception to read as follows:

Exception No. 2: The requirements for selective coordination described are not required where the legally required standby system was installed prior to June 1, 2006. For new legally required standby systems that are supplied from an existing legally required standby system installed prior to June 1, 2006, the new portion of the legally required standby system shall comply with NEC 701.18. The ground fault sensing function of overcurrent protective devices will only be required to selectively coordinate with the ground fault sensing functions of other overcurrent protective devices.

702.7 Optional Standby Systems - Signs

Article 702.7 of the National Electrical Code is amended and supplemented by the addition of the following paragraph prior to subsection (A) to read as follows:

Signs required in this section must be placed at the service disconnecting means and the meter base if the service disconnecting means and meter base are not located within sight and within 5 feet of each other

705 Interconnected Electric Power Production Sources

Article 705.1 of the National Electrical Code is amended and supplemented by the addition of the following paragraph following the first paragraph.

705.1 For utility interactive systems, any person making interconnections between a power production source and the utility distribution network must consult the serving utility and is required to meet all additional utility standards.

705.11 Supply-Side Source Connections

Article 705.11 of the National Electrical Code is amended and supplemented by the addition of the following paragraph following the first paragraph to read as follows:

In addition to the requirements of NEC 705.11, electric power production source conductors connected to the supply side of the service disconnecting means must be installed using wiring methods specified for service conductors in WCEC 230.43 and be grouped with the service disconnect(s). The disconnecting means providing overcurrent protection for the electric power production source conductors must comply with NEC 230.82(6). Grounding and bonding must be in accordance with NEC 250.25.

705.12 Point of Connection

Article 705.12 of the National Electrical Code is amended and supplemented by the addition of the following paragraph following the first paragraph to read as follows:

The output of an interconnected electric power source shall not be permitted to be connected to the load side of a disconnecting means that consists of a split-buss panelboard.

725.3 Class 1, Class 2, and Class 3 Remote-Control, Signaling, and Power - Limited Circuits Other Articles

Article 725.3 of the National Electrical Code is amended and supplemented by the addition of Subsection (Q) to read as follows:

(Q) Suspended Ceilings. The installation of Class 1, Class 2 and Class 3 circuits must comply with Section 300.11(A).

760.3 Fire Alarm Systems - Other Articles

Article 760.3 of the National Electrical Code is amended and supplemented by the addition of a new subsection (P), to read as follows:

(P) Suspended Ceilings. The installation of fire alarm cables and raceways installed in hollow spaces of suspended ceilings shall comply with Section 300.11(A) of this code.

760.12 Fire Alarm Systems

Article 760 of the National Electrical Code is amended and supplemented by the addition of a new Section 760.12 to read as follows:

760.12 Detection and Control Systems. Wiring for fire detection systems providing power, detection, or control input or output signals to mechanical smoke control systems, stair and elevator pressurization systems or elements thereof shall be fully enclosed within a continuous metallic raceway system. The installation of the wiring system shall be installed in accordance with this Article (NEC 760-Fire Alarm Systems), IBC Section 403 HIGH-RISE BUILDINGS, IBC Section 405 UNDERGROUND BUILDINGS and IBC Section 909 SMOKE CONTROL SYSTEMS as amended and adopted by the City Building Code. The installation shall ensure the survivability of circuits for the specified time for evacuation of the building as determined by the Fire Code Official.

760.30(A)&(B) Boxes

Article 760.30 of the National Electrical Code is amended and supplemented by the addition of new text to follow the end of the first paragraph, to read as follows:

(A) Fire Alarm Systems. Device and junction boxes for fire alarm systems shall be red in color, both inside and outside. Power-limited fire protective signaling circuit conductors shall be durably and plainly marked in or on junction boxes or other enclosures to indicate that it is a power-limited fire protective signaling circuit.

(B) Smoke Control Systems. All device boxes, junction boxes and enclosures for smoke control systems larger than 6 inches by 6 inches shall be permanently marked with an identification plate that is red in color with a yellow diagonal stripe so they will be readily identified as a component of the smoke control circuit or system. All other device and junction boxes for smoke control systems and circuits shall be red in color both inside and outside. Cover plates shall be red in color with a yellow diagonal stripe.

770.3 Optical Fiber Cables - Other Articles

Article 770.3 of the National Electrical Code is amended and supplemented by the addition of Subsection (D) to read as follows:

(D) Suspended Ceilings. The installation of optical fiber cables and raceways must comply with Section 300.11(A).

800.3 Communications Circuits - Other Articles

Article 800.3 of the National Electrical Code is amended and supplemented by the addition of Subsection (I) to read as follows:

(I) Suspended Ceilings. The installation of communications cables must comply with Section 300.11(A).

800.30 Communication Circuits

Article 800 of the National Electrical Code is amended and supplemented by the addition of a new Section 800.30 to read as follows:

800.30 Designation of Telecommunications Network Demarcation Point

- A. At the point of telecommunications network demarcation, the telecommunications installer must install an identification plate with the following information:
- 1) "Point of demarcation";
 - 2) Name of telecommunications utility; and
 - 3) Name of customer/end user of the system. (B) The telecommunications installer must confer with the telecommunications utility when determining the point of demarcation.