

This Tip Sheet reflects code requirements of the 2015 International Residential Code (IRC) w/ Washington State Amendments and the 2015 WA State Energy Code (WSEC).

Converting an Existing Garage

Converting your existing garage (or a portion of it) into living space will require a building permit. Any plumbing, electrical or mechanical work being done will also require a permit(s). Check with your local jurisdiction for permit submittal requirements. The new living space will be required to comply with current residential code and energy code requirements. Because converting your garage removes parking spaces, your property will most likely need to have alternative off-street parking. Verify parking requirements with your local jurisdiction.

Plans are Required

Building plans illustrating the proposed work are required to be submitted at the time of permit application. Floor plans should include the arrangement of all new and existing walls, and the dimensions and use of each space. Indicate all window and door openings. Show the locations of all smoke alarms, carbon monoxide alarms, stairs, exhaust fans, plumbing fixtures, and mechanical equipment. Smoke and carbon monoxide alarms will be required in the converted garage and throughout the existing residence. Provide information on how the space will comply with the current Energy Code requirements. Provide one or more cross-section(s) indicating floor, ceiling and roof construction. Indicate the ceiling height and identify all materials used in construction. Include information on the slab thickness and footings.

Sleeping Rooms

All new sleeping rooms are required to have at least one emergency escape and rescue opening. See [Tip Sheet 10](#) for more information. Smoke and carbon monoxide alarms are required outside of and in the immediate vicinity of all sleeping areas and a smoke alarm is required within each bedroom. See [Tip Sheet 4](#) for more information. Sleeping rooms shall not have windows or doors that open into a garage.

Creating a Curb in the Garage Door Opening

Details below provide information on how to replace the garage door opening with a wall, and assumes that the driveway slopes away from the house. If the grade slopes toward the house, discuss options with your local jurisdiction.

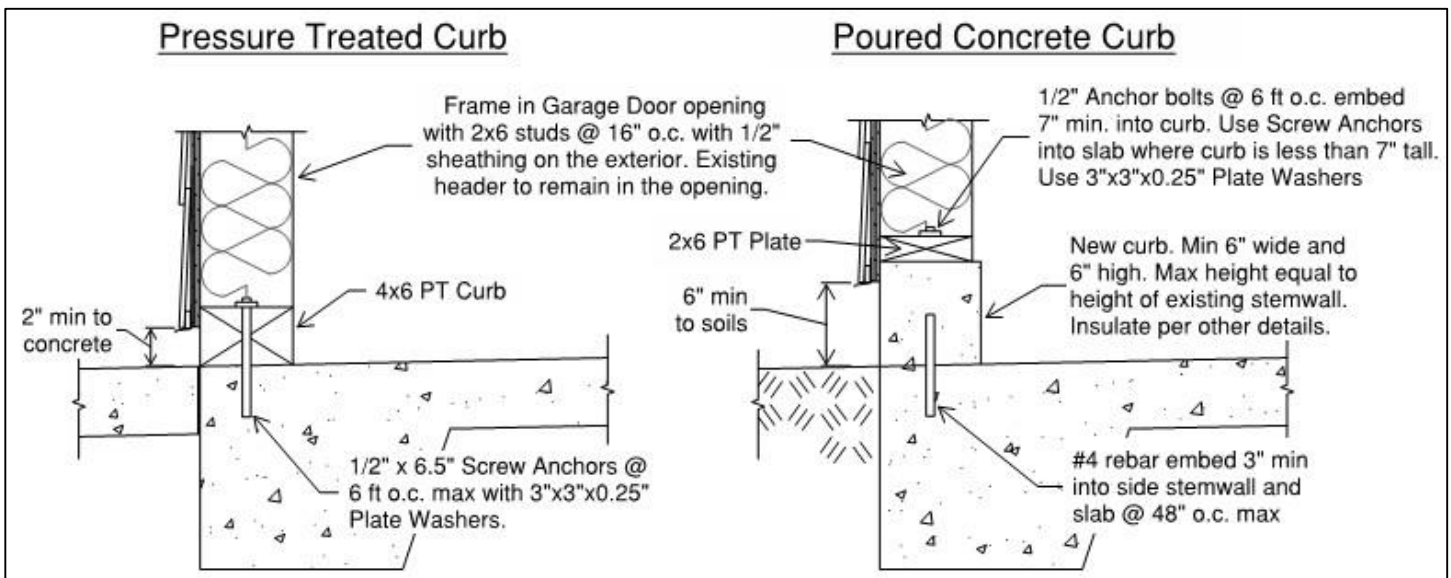

GENERAL INFORMATION:

- The intent of this Tip Sheet is to provide a general understanding of the code requirements and does not address the subject in great detail.
- Additional information can be obtained from your local participating jurisdiction.

Creating a New Footing Under the Slab

Some existing garage slabs will not have a thickened footing that runs beneath the slab in the garage door opening. In these cases it is often required to dig under the slab and add a footing to support the new wall above. The figure to the right shows one way that can be done. For other options speak to your jurisdiction. Excavation may be required to verify the existing slab thickness.

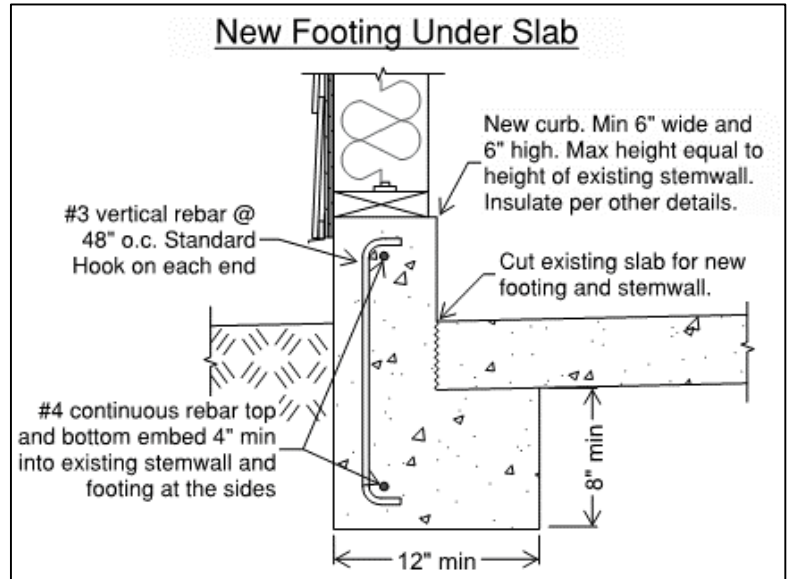

Energy Code Requirements

If your project does not meet the energy code requirements below, speak with your local jurisdiction for alternative options to comply with the energy code.

Windows and Exterior Doors

Windows and exterior doors located in the newly conditioned space must have a maximum U-factor of 0.30. Replacement of existing windows and doors may be required.

Attic Space

The attic space above the newly conditioned area is required to have R-49 insulation and be ventilated with a minimum vent area of 1/150 of the area of the vented space (1/300 if 40% - 50% of the vents are within 3' vertically of the ridge). Attics with a height of 30" or more and an area of 30 square feet or more must have a minimum 22" x 30" access opening.

Insulating Walls Above and Below Grade

Portions of the existing foundation enclosing conditioned space are required to be insulated per one of the details below.

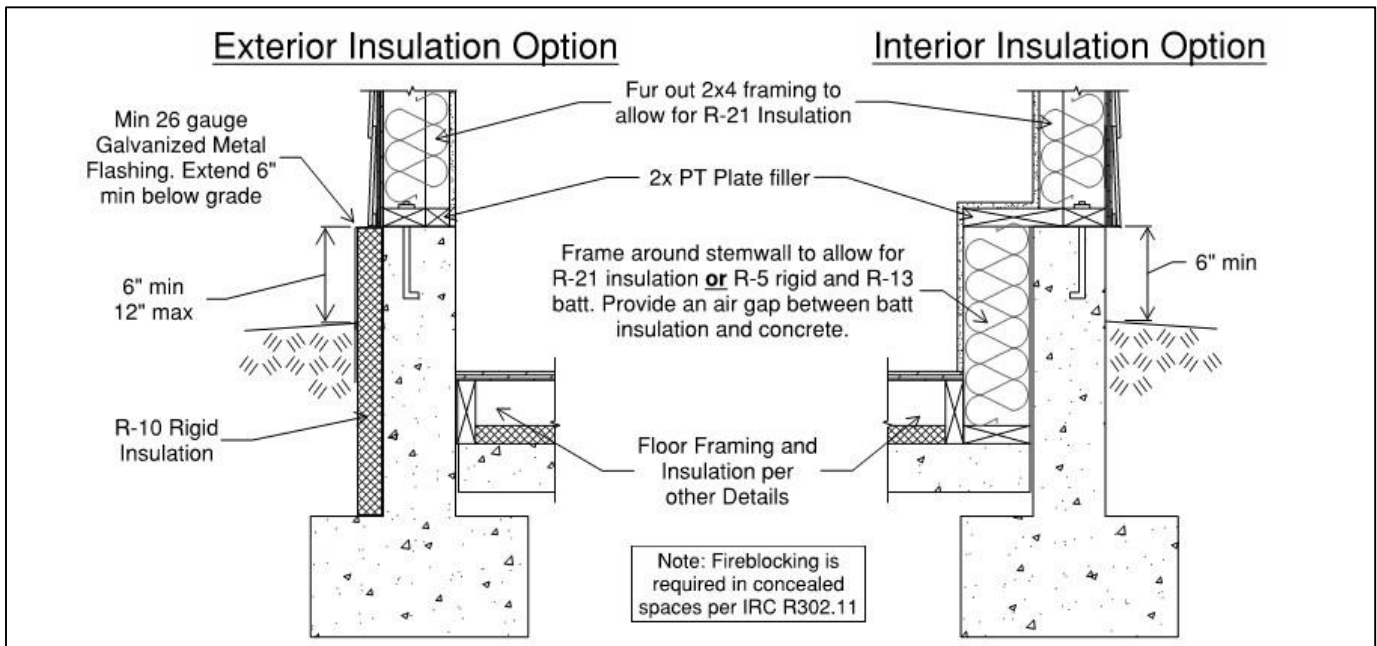

GENERAL INFORMATION:

- The intent of this Tip Sheet is to provide a general understanding of the code requirements and does not address the subject in great detail.
- Additional information can be obtained from your local participating jurisdiction.

Floor Insulation

The floor of the newly conditioned area is required to be insulated. While the energy code requires insulation under the slab, we realize that removing and replacing portions of the slab is difficult. Here are two approved insulation options above the slab that are equivalent to under slab insulation. Note: If batt insulation is to be used in raised framing without the R-7.5 rigid insulation indicated below, the minimum value is R-30, and the space below the floor joists will either need to be ventilated or filled to capacity with rigid insulation.

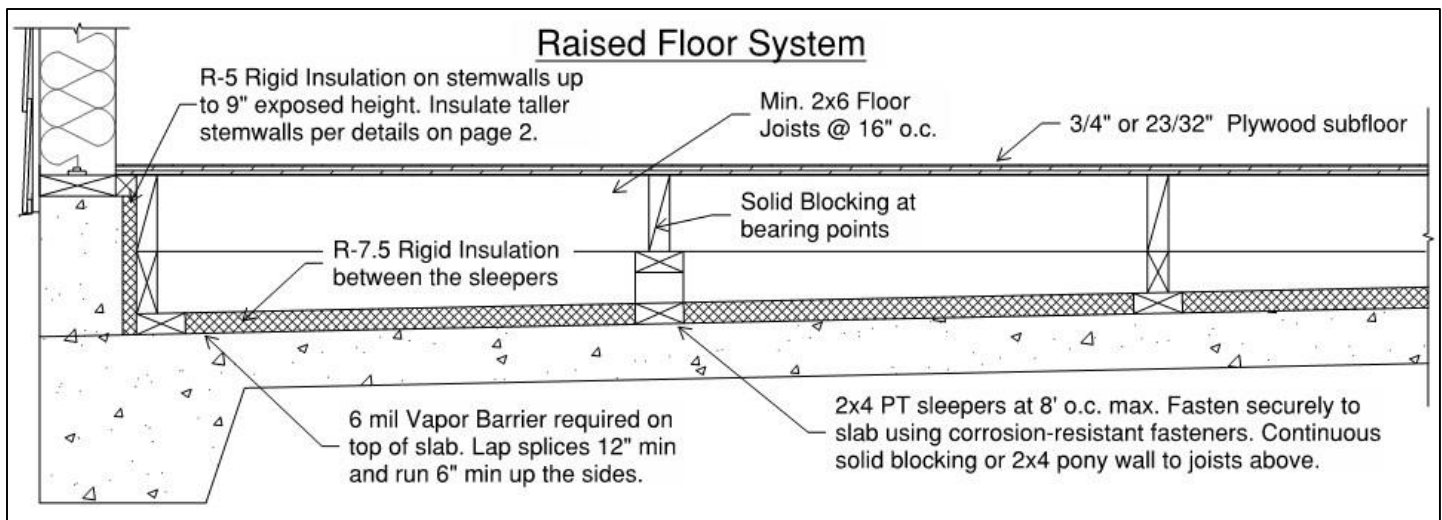
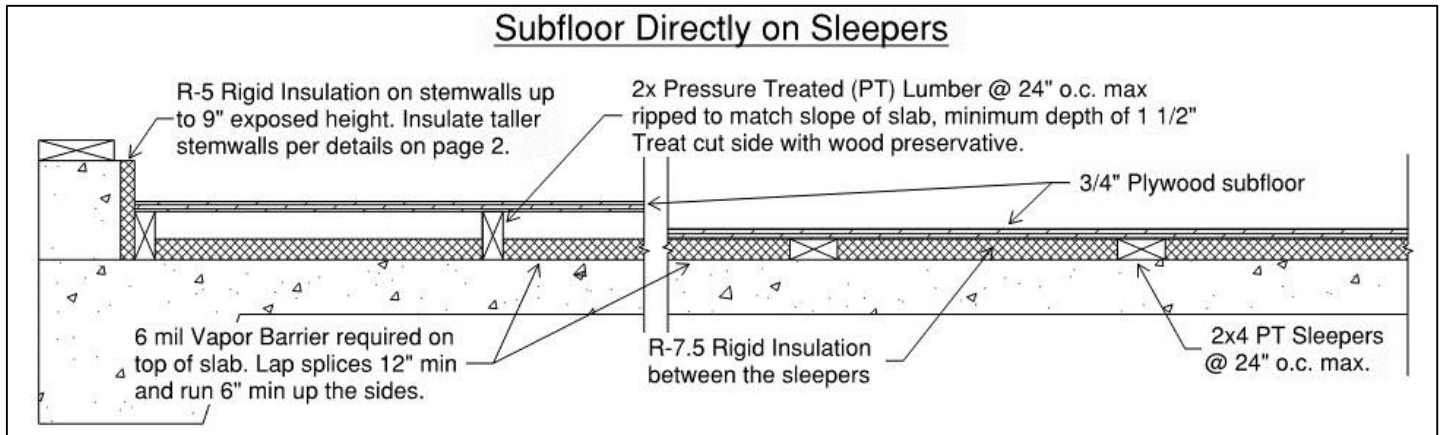

Additional Energy Credits

The WA State Energy Code requires additional energy credits when adding conditioned space to a dwelling. These credits are based on the size of the added space, with 0.5 credits for adding less than 500 sf, and 1.5 credits for adding less than 1,500 sf. See WSEC Section R406 for a complete list of options. Common options chosen are:

- Option 3a (1.0 Credits) – A gas, propane or oil-fired furnace with a min AFUE of 94%.
- Option 3d (1.0 Credits) – Ductless Split System Heat Pump located in the main zone of the addition.
- Option 5a (0.5 Credits) – All new showerhead and kitchen sink faucets rated at 1.75 GPM or less and all new lavatory faucets rated at 1.0 GPM or less.
- Option 5b (1.0 Credits) – A gas, propane or oil-fired water heater with a min EF of 0.74.
- Option 5c (1.5 Credits) – A gas, propane or oil-fired water heater with a min EF of 0.91.

GENERAL INFORMATION:

- The intent of this Tip Sheet is to provide a general understanding of the code requirements and does not address the subject in great detail.
- Additional information can be obtained from your local participating jurisdiction.