



CONSTRUCTION TIP SHEET 0
Single Family Residential
Permits When Required

August 2009

2006 IRC

PERMITS

No building or electrical, mechanical, or plumbing system shall be constructed, enlarged, altered, repaired, moved, demolished, or changed unless a permit has been obtained. Building, electrical, mechanical, plumbing, tree and grading permits may be required.

PERMITS REQUIRED (Building or other)
 (Common examples include but are not limited to the following)

1. Carports.
2. Decks more than 30" above grade (All decks in Mukilteo and SeaTac require permits).
3. Dock repairs and additions.
4. Exterior doors, windows and skylights that require a new opening (Replacement using existing openings in Bothell require permits).
5. Electrical circuits and service.
6. Fireplaces, wood-burning stoves, and inserts.
7. Garage conversions.
8. Home-business conversions (Check with local jurisdictions for exceptions).
9. Interior remodels.
10. Mother-in-law apartments.
11. Furnaces, water heaters, generators, heat pumps & AC units.
12. New hose bibs or drinking fountains.
13. Irrigation systems (Backflow only in Burien).
14. Gas piping.
15. Rockeries and retaining walls over 4' in height, those supporting a surcharge or located in a sensitive area.
16. Spas or saunas over 2' deep, in-ground or above ground swimming pools over 5,000 gallons.
17. Tree and vegetation removal, soil removal or additions (contact your jurisdiction for details)
18. Residential re-roof overlay (Bothell, SeaTac, Mill Creek and Kenmore only).
19. Re-roof involving structural elements, including but not limited to sheathing, skylights, change of roof pitch, addition or relocation of mechanical units, and change of roof material where the total weight exceeds 10 psf. (pounds per square foot)
20. Envelope inspection required for exterior cladding (Woodinville only).

PERMITS NOT REQUIRED (Building or other)
 (Common examples) *See footnotes below

1. One-story detached accessory structures used as tool and storage sheds, tree-supported play structures, playhouses, and similar uses not exceeding 200 s.f. (120 s.f. in Kirkland, Burien, Mukilteo, Mill Creek, Snoqualmie and SeaTac).
2. Fences not over 6' high (for Bellevue: fences not over 8' high)(Permit required in Mill Creek).
3. Retaining walls or rockeries which are not over 4' in height measured from the bottom of the footing to the top of the wall unless located in a sensitive area, is supporting a surcharge or supporting sloped ground. (see page 2)
4. Sidewalks, decks, and driveways not more than 30" above grade and not over a basement or story below (SeaTac and Mukilteo: all decks require permits).
5. In-kind re-roofing provided roof sheathing is not removed, replaced or added (Permit required in Snoqualmie, SeaTac and Bothell).
6. Replacement of decking on docks and decks without replacement of any other structural members. Handrails replacement requires a permit.
7. Painting, papering, tiling, carpeting, cabinets, countertops, and similar finish work.
8. Swings, slides, and other playground equipment.
9. Window awnings supported by an exterior wall which do not project more than 54" and do not require additional support.
10. Bathroom and kitchen fixture replacements without plumbing line modifications such as sinks and toilets.
11. Appliance replacement in the same location without modification to gas, plumbing lines, or electrical circuits such as dishwashers, ranges, ovens, gas logs, washers, and dryers.
12. Residential re-roof overlay if limited to 2 total layers of roofing material. (Note: Permit required in Bothell and Kenmore)
13. Electrical permit not required to replace existing switches or receptacles within an existing box.

GENERAL INFORMATION:

- Although a building permit is not required, consult with your local planning department regarding required zoning regulations such as setbacks, structure heights, impervious surface limitations, etc.
- The intent of this sheet is to address the requirements of when a building permit is required. For residential projects, please contact your local building department regarding specific questions not addressed here or requiring further clarification.

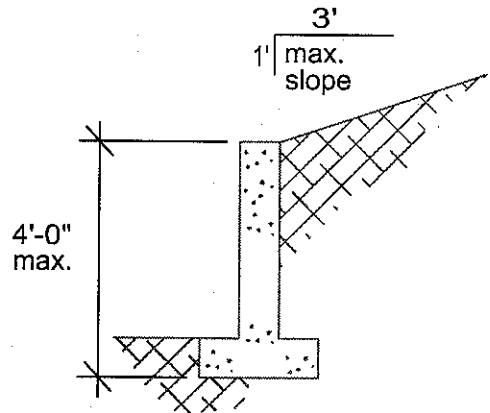

Low slope retaining wall:
No permit required

NOTE:
Verify location of utilities and easements before starting the work.
Call before you dig.
Phone: 1-800-424-5555

